



Associate editor: B.L. Roth

## Hallucinogens

David E. Nichols\*

*Department of Medicinal Chemistry and Molecular Pharmacology, School of Pharmacy and Pharmacal Sciences,  
Purdue University, West Lafayette, IN 47907-2091, USA*

### Abstract

Hallucinogens (psychedelics) are psychoactive substances that powerfully alter perception, mood, and a host of cognitive processes. They are considered physiologically safe and do not produce dependence or addiction. Their origin predates written history, and they were employed by early cultures in a variety of sociocultural and ritual contexts. In the 1950s, after the virtually contemporaneous discovery of both serotonin (5-HT) and lysergic acid diethylamide (LSD-25), early brain research focused intensely on the possibility that LSD or other hallucinogens had a serotonergic basis of action and reinforced the idea that 5-HT was an important neurotransmitter in brain. These ideas were eventually proven, and today it is believed that hallucinogens stimulate 5-HT<sub>2A</sub> receptors, especially those expressed on neocortical pyramidal cells. Activation of 5-HT<sub>2A</sub> receptors also leads to increased cortical glutamate levels presumably by a presynaptic receptor-mediated release from thalamic afferents. These findings have led to comparisons of the effects of classical hallucinogens with certain aspects of acute psychosis and to a focus on thalamocortical interactions as key to understanding both the action of these substances and the neuroanatomical sites involved in altered states of consciousness (ASC). In vivo brain imaging in humans using [<sup>18</sup>F]fluorodeoxyglucose has shown that hallucinogens increase prefrontal cortical metabolism, and correlations have been developed between activity in specific brain areas and psychological elements of the ASC produced by hallucinogens. The 5-HT<sub>2A</sub> receptor clearly plays an essential role in cognitive processing, including working memory, and ligands for this receptor may be extremely useful tools for future cognitive neuroscience research. In addition, it appears entirely possible that utility may still emerge for the use of hallucinogens in treating alcoholism, substance abuse, and certain psychiatric disorders.

© 2003 Elsevier Inc. All rights reserved.

*Keywords:* Hallucinogen; 5-HT<sub>2A</sub> receptors; Prefrontal cortex

### Contents

1. Introduction . . . . .	132
1.1. Historical perspective . . . . .	133
1.2. Toxicity and addiction . . . . .	134
2. The chemical classes of hallucinogens . . . . .	135
3. Psychopharmacological effects of hallucinogens . . . . .	137
4. How do hallucinogens work? . . . . .	138
4.1. Historical relationship between serotonin and hallucinogen action . . . . .	138
4.2. Early hypothesis for a presynaptic agonist mechanism of action . . . . .	139
4.3. Evidence for agonist activity at the serotonin <sub>2A</sub> receptor subtype . . . . .	139
4.3.1. Relevance of animal models to man: species differences in receptors . . . . .	143
4.3.2. Signaling through the serotonin <sub>2A</sub> receptor: agonist trafficking. . . . .	143
4.3.3. Neuroanatomical localization of serotonin <sub>2A</sub> receptors . . . . .	145
4.3.4. Functional consequences of serotonin <sub>2A</sub> receptor activation in prefrontal cortex . . . . .	148
4.3.4.1. Effects on cortical glutamate . . . . .	149
4.3.4.2. Hallucinogens increase cortical metabolism . . . . .	154
4.3.4.3. Dopaminergic effects of hallucinogens . . . . .	155
4.3.4.4. Serotonin <sub>2A</sub> receptor activation alters gene expression . . . . .	156

\* Fax.: +1-765-49-414-61.

*E-mail address:* [david.e.nichols.1@purdue.edu](mailto:david.e.nichols.1@purdue.edu) (D.E. Nichols).

4.4.	Are other receptors important to the actions of hallucinogens? . . . . .	157
4.4.1.	A role for the serotonin <sub>2C</sub> receptor subtype . . . . .	158
4.4.2.	Is the serotonin <sub>1A</sub> receptor important? . . . . .	158
4.4.3.	Possible potentiating effects of interactions at other receptor subtypes. . . . .	160
5.	Clinical relevance of serotonin <sub>2A</sub> receptors . . . . .	162
5.1.	Lysergic acid diethylamide treatment in terminal illness. . . . .	163
5.2.	Treatment of alcoholism and substance abuse . . . . .	163
5.3.	Obsessive-compulsive disorder . . . . .	164
5.4.	Clinical studies of <i>N,N</i> -dimethyltryptamine . . . . .	164
5.5.	Studies of mescaline . . . . .	165
5.6.	Studies of psilocybin . . . . .	165
5.7.	Effects on cognition and perception: future tools for cognitive neuroscience . . . . .	166
6.	Conclusions . . . . .	168
	Acknowledgments . . . . .	168
	References . . . . .	168

## 1. Introduction

What are hallucinogens? This term was originally coined because of the notion that these substances produce hallucinations, an effect, however, that they do not ordinarily elicit, at least at typical dosages. Thus, that name is a misnomer. Today, unfortunately, hallucinogen appears almost to have become a catchall category, often representing pharmacological substances ranging from cannabinoids and *N*-methyl-D-aspartate (NMDA) antagonists to anticholinergic agents, ecstasy (MDMA; 3,4-methylenedioxymethamphetamine), and many others. The common theme of all these classes of pharmacologically active substances is that they alter consciousness, often in dramatic and unpredictable ways, and in high doses may produce delirium, true hallucinations, loss of contact with reality, and in some cases death. To describe at least some of those substances, the term “psychotomimetic” (psychosis mimicking; Hoffer, 1967), widely used for many years, seems more appropriate.

Ecstasy, presently a popular recreational drug, has in some cases also been called a hallucinogen because it has subjective effects that are to a certain degree similar, including altered time perception and changes in visual perception. MDMA has unique psychopharmacology, however, appearing to have major components of action that involve interaction with monoamine uptake transporters, and does not properly fit within the hallucinogen classification (Nichols & Oberlender, 1990; Nichols, 1994; Bankson & Cunningham, 2001; O’Leary et al., 2001). Thus, one needs to be very specific about definitions when “hallucinogens” are being discussed.

Hallucinogens, for the purposes of this review, will mean only substances with psychopharmacology resembling that of the natural products mescaline and psilocybin and the semisynthetic substance known as lysergic acid diethylamide (LSD-25). More specifically, now that there is appreciation of their probable molecular mechanism of action, we shall review those substances that principally exert their central nervous system (CNS) effects by an agonist (or partial agonist) action at serotonin (5-HT)<sub>2A</sub> receptors.

Many different names have been proposed over the years for this drug class. The famous German toxicologist Louis Lewin used the name *phantastica* earlier in this century (Lewin, 1964), and as we shall see later, such a descriptor is not so farfetched. The most popular names, hallucinogen, psychotomimetic, and psychedelic (“mind manifesting”; Osmond, 1957), have often been used interchangeably. Hallucinogen is now, however, the most common designation in the scientific literature, although it is an inaccurate descriptor of the actual effects of these drugs. In the lay press, the term psychedelic is still the most popular and has held sway for nearly four decades. Most recently, there has been a movement in nonscientific circles to recognize the ability of these substances to provoke mystical experiences and evoke feelings of spiritual significance. Thus, the term entheogen, derived from the Greek word *entheos*, which means “god within,” was introduced by Ruck et al. (1979) and has seen increasing use. This term suggests that these substances reveal or allow a connection to the “divine within.” Although it seems unlikely that this name will ever be accepted in formal scientific circles, its use has dramatically increased in the popular media and on internet sites. Indeed, in much of the counterculture that uses these substances, entheogen has replaced psychedelic as the name of choice and we may expect to see this trend continue.

There is only a meager amount of factual information about hallucinogenic drugs among the general public today. Furthermore, in the scientific and medical communities, where one expects to find expertise on drugs, there is now a whole generation who knows almost nothing about hallucinogens other than the fact that they are subject to the strictest legal controls applied to any class of pharmacological agents. These drugs presently lack demonstrated therapeutic utility and still remain, as they have for more than 50 years, pharmacological curiosities. Research efforts directed toward examining their potential medical utility are extremely limited not only in the United States but also internationally. Studies of the mechanism of action of hallucinogens are still incomplete and have not attracted a high level of scientific interest for more than four decades.

We know relatively little about how they affect the brain in spite of their continued popularity as recreational drugs among a significant proportion of the population.

Despite their high degree of physiological safety and lack of dependence liability, hallucinogens have been branded by law enforcement officials as among the most dangerous drugs that exist, being placed into Schedule I of the Controlled Substances Act. Depending on the locale, especially in the United States, punishments for using or distributing drugs like LSD are often more draconian than if the user had committed a violent crime. Although there is a common perception that Schedule I drugs are particularly dangerous, the 3-pronged test for placement of a drug into schedule I requires only that (1) the drug has no currently accepted medical use in the United States, (2) there is a lack of safety for use of the drug under medical supervision, and (3) the substance has a high “potential for abuse.” The practical consequence of this scheduling means that applications and procedures to gain approval to carry out research with them, especially in humans, are very burdensome. This situation is true virtually everywhere in the world, although in a few European countries, most notably in Switzerland, a more progressive attitude has recently prevailed. Within the past decade, there appears to have been a resurgence of research interest in these substances as well as the initiation of several new clinical studies, even in the United States.

What is it, exactly, that makes these pharmacological curiosities so fearsome? The answer lies, in large measure, beyond hard science and within a complex sociological and political agenda that surround psychedelics, which is well outside the scope of this review. Nevertheless, a very brief discussion of the history and background of these unique substances is warranted to provide a little insight into how this situation arose.

### 1.1. Historical perspective

Naturally occurring hallucinogenic drugs played a significant role in the development of philosophy and religious thought in many earlier cultures. One can argue persuasively that hallucinogenic drugs might have been catalysts for the development of humankind’s earliest philosophies and theologies. How many Neolithic hunters, one might wonder, eking out an existence in the wild, were likely to sit before the fire at night contemplating the nature of man and the meaning of life? By contrast, if the same group had discovered and ingested some hallucinogenic mushrooms, they would be compelled to confront and would surely have discussed and attempted to understand the nature of their otherworldly mushroom-induced encounters. Assuming that their neurochemistry was not so different from ours today, those occurrences would have been well beyond the bounds of their everyday experiences and vocabulary. They could easily have concluded that these plants were “the residences of divinities or other spiritual forces” (Schultes & Hofmann, 1979).

Well-documented and important examples of hallucinogen use in other cultures include the *soma* of ancient India (Wasson & Ingalls, 1971) to which numerous Vedic hymns were written, *teonanacatl*, “god’s flesh” used by the Aztec shaman (Ott & Bigwood, 1978; Schultes & Hofmann, 1979), and *peyote* taken as a sacrament during services of the Native American Church (Stewart, 1987). In Mexico, there were about 40 plants, some of which still remain unidentified, that were used ritually or were regarded as sacred (Diaz, 1977). In the village of Eleusis in ancient Greece, for more than 2000 years, it was a treasured opportunity for any Greek citizen who had not been convicted of murder to participate in the secret all-night ceremony each September that involved the drinking of a special potion known as κῠκεον. Today, we know very little about this ceremony, but reasonable arguments have been made that κῠκεον was some sort of hallucinogenic brew. The ritual was partially described in the 2nd century A.D.: “. . . of all the divine things that exist among men, it is both the most awesome and the most luminous” (Wasson et al., 1978). Today, in modern Brazil, a respected religion uses *ayahuasca* as a sacrament, a psychoactive plant decoction containing the hallucinogen *N,N*-dimethyltryptamine (DMT) combined with  $\beta$ -carboline monoamine oxidase inhibitors that confer it with oral activity (McKenna & Towers, 1984; McKenna et al., 1984; Callaway et al., 1996; Grob et al., 1996; Riba et al., 2002, 2003; Yritia et al., 2002). *Ayahuasca*, also known as *yagé* or *hoasca*, has a long history of ceremonial use by natives in the Amazon valley of South America (Dobkin, 1971; Schultes & Hofmann, 1979).

What exactly are these substances feared by modern man yet held sacred and even worshipped by ancient cultures? Jaffe (1990) provided a definition that is most consistent with their ritual use in other cultures. Arguing that the name psychedelic is better than either hallucinogen or psychotomimetic, he stated “. . . the feature that distinguishes the psychedelic agents from other classes of drugs is their capacity reliably to induce states of altered perception, thought, and feeling that are not experienced otherwise except in dreams or at times of religious exaltation.” The late Daniel X. Freedman, one of the great pioneers of LSD research, made comments consistent with that assessment, stating, “. . . one basic dimension of behavior. . . compellingly revealed in LSD states is “portentousness”—the capacity of the mind to see more than it can tell, to experience more than it can explicate, to believe in and be impressed with more than it can rationally justify, to experience boundlessness and “boundaryless” events, from the banal to the profound.” (Freedman, 1968). It might be noted in this context that one doctoral dissertation has even provided evidence that psilocybin-induced mystical-religious experiences could not be distinguished, by objective criteria, from spontaneously occurring ones (Pahnke, 1963).

Although these descriptions focus on the more spectacular effects that these substances are capable of producing, low doses *generally* elicit less dramatic results. Typical

clinical effects of hallucinogens would include the following (Hollister, 1984):

1. *Somatic symptoms*: dizziness, weakness, tremors, nausea, drowsiness, paresthesias, and blurred vision.
2. *Perceptual symptoms*: altered shapes and colors, difficulty in focusing on objects, sharpened sense of hearing, and rarely synesthesias.
3. *Psychic symptoms*: alterations in mood (happy, sad, or irritable at varying times), tension, distorted time sense, difficulty in expressing thoughts, depersonalization, dreamlike feelings, and visual hallucinations.

It should be apparent from the foregoing discussion that hallucinogens have a unique and powerful ability to affect the human psyche. They may alter one's concepts of reality, may change one's views on life and death, and can provoke and challenge one's most cherished beliefs. Therein, this writer believes, lay the roots of much of the fear and hysteria that these substances have fostered in our society. Numerous books and treatises have been written on all aspects of the subject of hallucinogens, and previous scientific reviews on the subject can be consulted to supplement the present discussion (Cohen, 1967; Freedman, 1969; Nieforth, 1971; Brawley & Duffield, 1972; Brimblecombe, 1973; Brimblecombe & Pinder, 1975; Siva Sankar, 1975; Boarder, 1977; Hollister, 1978, 1984; Shulgin, 1978, 1981; Nichols, 1981, 1986, 1997; Jacobs, 1984; Nichols et al., 1991a; Strassman, 1995; Abraham et al., 1996; Marek & Aghajanian, 1998b; Aghajanian & Marek, 1999a).

### 1.2. Toxicity and addiction

Hallucinogens are generally considered to be physiologically safe molecules whose principal effects are on consciousness. That is, hallucinogens are powerful in producing altered states of consciousness (ASC), but they do so at doses that are not toxic to mammalian organ systems. There is no evidence that any of the hallucinogens, even the very powerful semisynthetic LSD, causes damage to any human body organ. Cohen (1967) has stated, "Death directly caused by the toxicity of LSD is unknown." This statement was reiterated 20 years later by Jaffe (1985), "In man, deaths attributable to direct effects of LSD are unknown." This observation still remains true today. Hallucinogens do not cause life-threatening changes in cardiovascular, renal, or hepatic function because they have little or no affinity for the biological receptors and targets that mediate vital vegetative functions.

In contrast to many other abused drugs, hallucinogens do not engender drug dependence or addiction and are not considered to be reinforcing substances (O'Brien, 2001). It is generally believed that most if not all drugs that possess dependence liability have the ability to affect dopaminergic (DA) transmission, particularly in mesolimbic

areas of the brain. The behavioral correlate of this effect is increased mood and often euphoria. By contrast, nearly all hallucinogens lack affinity either for DA receptors or for the DA uptake transporter and therefore do not directly affect DA neurotransmission. In an article reviewing drugs of abuse that activate brain reward pathways, drugs identified with this action included opiates, nicotine, cannabis, phencyclidine (PCP), cocaine, amphetamine, alcohol, benzodiazepines, barbiturates, and even caffeine, but there was no mention of hallucinogens (Wise, 1998).

There are no literature reports of successful attempts to train animals to self-administer classical hallucinogens, an animal model predictive of abuse liability, indicating that these substances do not possess the necessary pharmacology to either initiate or maintain dependence. Hoffmeister (1975) has reported that LSD actually had negative reinforcing properties in rhesus monkeys trained in an avoidance task. LSD may have weak reinforcing effects in rats, however, because Parker (1996) reported that a relatively high dose of LSD (0.2 mg/kg i.p.) produced conditioned place preference (CPP) in rats, another animal model that is often predictive of the reinforcing quality of a drug. It is important to point out that this dose is sufficient to enable LSD to activate postsynaptic DA receptors, a pharmacological property that is unique to this hallucinogen. Using the same 0.2 mg/kg dose of LSD, Meehan and Schechter (1998) also reported that LSD produced CPP in male but not in female Fawn Hooded rats. The Fawn Hooded strain of rats, however, is differentially sensitive to serotonergic agents, and fenfluramine also produces CPP in these rats (Meehan & Schechter, 1994), whereas it produces aversion in Sprague-Dawley rats (Meehan & Schechter, 1994; Marona-Lewicka et al., 1996). Among all of the known hallucinogens, only LSD has high affinity for DA receptors (see, e.g., Watts et al., 1995; Giacomelli et al., 1998). Furthermore, although the acute behavioral effects of LSD are generally attributed to activation of 5-HT<sub>2A</sub> receptors, behavioral effects in rats occurring more than 1 hr after LSD administration recently have been reported to be primarily mediated by DA pathways (Marona-Lewicka & Nichols, 2002).

Strassman (1984) and Halpern and Pope (1999) have analyzed the published reports on adverse reactions and negative long-term sequelae following hallucinogen use. Halpern and Pope reached a conclusion similar to Strassman's earlier analysis that concerning repeated use of psychedelic drugs the results were controversial, but if any long-term adverse effect did occur it was "subtle or nonsignificant." It should be noted, however, that in both studies their conclusions were specifically developed based on reviews of supervised clinical research with hallucinogens.

One adverse consequence of hallucinogen use is known as "flashbacks." Flashbacks were widely dis-



cussed in the press, particularly in earlier decades, as one of the most common adverse effects of hallucinogens; their occurrence was emphasized as a deterrent to recreational use. A flashback essentially consists of the re-experiencing of one or more of the perceptual effects that were induced by hallucinogens but occurring after the effect of the drug has worn off or at some later time in the complete absence of the drug. Flashbacks most often appear as visual symptoms and can persist for months or in some cases years, and there appears to be no relationship between frequency of hallucinogen use and rate of occurrence. Recently, Halpern and Pope (2003) have reviewed the evidence on hallucinogen persisting perception disorder (HPPD), the *Diagnostic and Statistical Manual of Mental Disorders, Fourth Edition* category for flashbacks. First, they note that the term flashback itself has been defined in so many different ways that they believe it is now virtually useless. Second, they point out that when LSD was used in a therapeutic or research setting, HPPD appeared less frequently than when it was used recreationally. Finally, because of the different ways that flashbacks were defined, it is impossible to discern the true incidence of the disorder. They do conclude that at least for some individuals, particularly users of LSD, a long-lasting HPPD syndrome can occur with symptoms of “persistent perceptual abnormalities reminiscent of acute intoxication.” Based on the millions of people who have taken hallucinogens, the incidence of HPPD appears to be very small, and there is presently no effective treatment.

There are, however, real and significant dangers that can accompany recreational use of these substances. Although LSD or other classical hallucinogens have not directly caused overdose death, fatal accidents during LSD intoxication have occurred (Jaffe, 1985). This danger is significant, particularly when these drugs are used recreationally in unsupervised settings. Belief that one has superhuman powers while judgment is impaired by hallucinogens can lead to injury or death when an unsupervised user carries out dangerous activities such as walking out on a freeway or attempting to fly (see, e.g., Reynolds & Jindrich, 1985). Less serious but still very substantial injuries can occur in unusual ways. For example, severe and irreversible ocular damage has resulted from prolonged staring at the sun by individuals under the influence of LSD (Schatz & Mendelblatt, 1973; Fuller, 1976).

The most significant dangers of psychedelics, however, appear to lie principally in their psychological effects. LSD can induce disturbances of experience, otherwise observed only in psychoses, such as alteration of cognitive functions, and depersonalization. Hallucinogens can catalyze the onset of psychosis or depression, which has sometimes led to suicide, and Cohen (1960) has estimated the incidence of LSD-related psychosis to be about 8 per 10,000 subjects. In another study, one case of psychosis was reported in a survey of 247 LSD users (McGlothlin & Arnold, 1971). Fortunately,

however, these drugs do not appear to produce illness de novo in otherwise emotionally healthy persons, but these problems seem to be precipitated in predisposed individuals.

In atypical courses of intoxication, so-called bad trips, anxiety and excitement predominate. Bad trips can usually be treated successfully by “talk-down” therapy and administration of benzodiazepines. In an early report, Taschner and Wanke (1975) saw in their clinic several LSD users with psychoses. At the time, they classified them into “flashbacks, exogenic (toxic) psychoses, and so-called endoform psychoses.” They considered three possible explanations for the latter category: accidental coincidence of LSD use and onset of psychosis, preexisting psychosis with symptomatic use of LSD as an attempt at self-treatment, or finally the onset of psychosis triggered by the use of the hallucinogen. Based on the presenting symptoms, these patients could not be reliably distinguished from real schizophrenics.

A somewhat later study by Vardy and Kay (1983) compared patients hospitalized for LSD psychosis with first-break schizophrenics. In most respects, the LSD psychotics were fundamentally similar to schizophrenics in genealogy, phenomenology, and course of illness. Their findings support a model of LSD psychosis as a drug-induced schizophreniform reaction in persons vulnerable to both substance abuse and psychosis.

Although these studies demonstrate a significant danger of LSD use, the number of such reports is very small relative to the numbers of persons who are believed to have self-administered LSD in recreational settings. A search of Medline in early 2003 for case reports of LSD-induced psychosis found only three reports in the previous 20 years. Although nearly all of the reports that do exist focus attention specifically on the dangers of LSD, all of the hallucinogens can cause similar psychological reactions, and one might anticipate comparable results if the numbers of users of other hallucinogens had been correspondingly large.

## 2. The chemical classes of hallucinogens

The chemical structures of hallucinogens can be classified into two broad categories: (1) the tryptamines and (2) the phenethylamines. Within the tryptamines, however, one should probably include two subsets, the simple tryptamines such as DMT, 5-methoxy-DMT (5-MeO-DMT), and psilocybin, which possess considerable conformational flexibility, and the ergolines, relatively rigid analogues including LSD and a few very closely related compounds. It also should be pointed out that psilocybin is actually a prodrug for psilocin. That is, after ingestion of psilocybin, alkaline phosphatases in the digestive system, kidney, and perhaps in the blood readily cleave the *O*-phosphoryl ester to generate the hydroxy compound psilocin, which is the species that actually is biologically active (Horita & Weber, 1961; Horita, 1963; Hasler et al., 1997). Whenever a reference is made to the in vivo effects of psilocybin

(e.g., in the clinical studies discussed in later sections), it should be understood that the actual hallucinogenic species is psilocin.

The doses, duration of action, and routes of administration vary for the different classes of hallucinogens. The simple tryptamines DMT and 5-MeO-DMT are not active

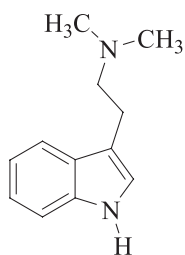

DMT

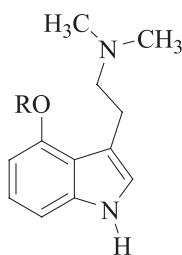

R = H; Psilocin  
R = PO<sub>3</sub>H; Psilocybin

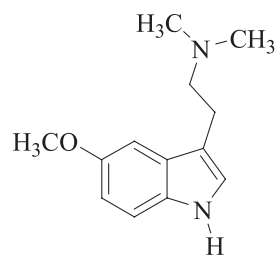

5-Methoxy-DMT

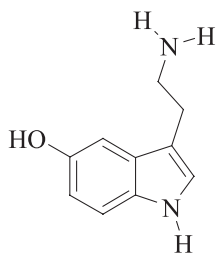

Serotonin; 5-HT

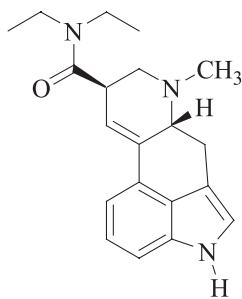

LSD

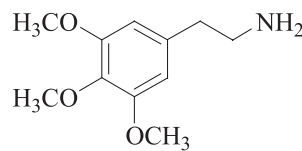

Mescaline

The prototype of the phenethylamines is the naturally occurring compound mescaline, the principal active component in the peyote cactus *Lophophora williamsii*. Extensive structure-activity relationship studies carried out over several decades principally in the laboratories of Nichols (1981, 1994, 1997), Glennon et al. (1986), Glennon (1989, 1999), Nichols et al. (1991a), and Shulgin and Shulgin (1991b) have led to a good general understanding of the structural and stereochemical features that lead to hallucinogenic activity in substituted phenethylamine derivatives. In this process, extremely potent compounds have also been discovered, and many of the resulting molecules have proven to be useful tools for studies of the mechanism of action.

For many years, medicinal chemists envisioned “ergoline-like” binding orientations for the phenethylamines that might suggest some structural congruence between the two types of classes on receptor binding (Marini-Bettolo et al., 1951; Barfknecht & Nichols, 1972; Glennon et al., 1983b). Recently, however, it seems unlikely that such a structural congruence exists and that various ligands may bind to and activate the receptor in a variety of different orientations (Monte et al., 1998; Chambers et al., 2003).

orally but are typically smoked or nasally insufflated. These were often the psychoactive components of native South American plant preparations that were used as snuffs. The dose of DMT is typically 60–100 mg of the free base and 6–20 mg for 5-MeO-DMT (Ott, 2001; Beyerstein et al., 2003). When smoked or injected, the onset of action for DMT is typically 10–15 sec. The duration of action for these simple tryptamines is very short, with the effects typically dissipated in less than 1 hr for DMT and 20–30 min for 5-MeO-DMT.

Psilocybin is orally active, with effective doses in the range of 6–20 mg. The onset of action is typically 20–30 min, with the effects completely gone within about 4–6 hr (Shulgin, 1980). The most detailed clinical studies of psilocybin have been reported by Vollenweider et al. (1998). Drug effects began 20–30 min after an oral dose of 0.25 mg/kg, peaked after another 30–50 min, and lasted another 1–2 hr. The greatest psychological effects occurred at about 80 min after drug administration and coincided with the peak plasma concentration of psilocin (Hasler et al., 1997).

Our modern awareness of hallucinogens began on Friday, April 16, 1943, when Albert Hofmann, a natural products chemist with Sandoz Pharmaceuticals in Basel, Switzerland, experienced unusual mental effects following work with

LSD-25, the diethylamide of lysergic acid (Hofmann, 1979, 1994). His suspicion that the effects he had experienced on the previous Friday were due to accidental exposure to a tiny unknown amount of LSD were confirmed three days later on April 19 by his deliberate oral ingestion of a solution containing 0.25 mg of LSD tartrate, a relatively large dose of this substance. On that occasion, the effects were very profound and left no doubt that the unusual intoxication of the previous Friday had been due to ingestion of LSD. No drug had been discovered up to that time that possessed such high potency, so the research management at Sandoz was initially skeptical of Dr. Hofmann's report. Nevertheless, several other scientists at the company ingested this new substance (albeit in smaller doses) and confirmed its remarkable psychopharmacology. LSD (tartrate) is p.o. active and is the most potent of all the hallucinogens, with doses ranging from 0.05 to 0.20 mg. Doses as low as 0.025 mg can be detected in some individuals. Dosage forms available on the illicit market today are typically 0.04–0.06 mg, whereas in past years they were more often in the 0.10–0.20 mg range; in the late 1960s, tablets were often found that contained 0.25 mg or more. LSD is also very long acting, with effects that can last as long as 10–12 hr.

Mescaline is also orally active but is the least potent of all the classical hallucinogens. Despite its low potency, mescaline has served as a prototype hallucinogen because of the similarity of its psychopharmacology to the other hallucinogens and also because it is still extensively used up to the present day in the form of *peyote* during religious services of the Native American Church. It also has served as the lead molecule in structure-activity relationship studies of the phenethylamines, leading ultimately to extremely potent substituted amphetamines such as 2,5-dimethoxy-4-bromoamphetamine (DOB) and 2,5-dimethoxy-4-iodoamphetamine (DOI). Mescaline is also a long-acting compound, with effects that can last up to 10–12 hr; effective doses of the sulfate salt are in the 200–400 mg range (Shulgin, 1973; Beyerstein et al., 2003).

### 3. Psychopharmacological effects of hallucinogens

In contrast to virtually every other class of CNS drug, where the action is usually predictable, the effects of hallucinogens are heavily dependent on the expectations of the user (“set”) and the environment (“setting”) in which the use takes place. Indeed, no clinician experienced with these substances would fail to consider set and setting as *primary* determinants of the experience. Thus, expectations and environments that would foster religious or spiritual experiences increase the probability of the drug producing such an effect. Conversely, use in a nonstructured, unwise, or recreational way can have unpredictable and even disastrous psychological consequences. Early clinical research, where LSD was expected to produce a model psychosis (recall the term “psychotomimetic”), was not designed to discover

positive effects of these substances. Subjects given LSD in a clinical ward and counseled that they might experience schizophrenia-like symptoms indeed often did suffer panic, anxiety, negative effects, and feelings of insanity.

Dr. Stanislov Grof, who supervised more clinical LSD sessions than any other individual, wrote, “I consider LSD to be a powerful unspecific amplifier or catalyst of biochemical and physiological processes in the brain” (Grof, 1975). These thoughts were echoed by Barr et al. (1972) who stated, “. . .the phenomena induced by LSD (and probably by any similar drug) cannot be predicted or understood in purely pharmacological terms; the personality of the drug taker plays an enormous and critical role in determining how much effect there will be and of what particular type.” To complicate matters further, an individual subject's response to repeated administration of the same drug and dose may also vary.

Although greatest interest in hallucinogens often focuses on the more dramatic effects that they are capable of producing, low doses may elicit not only quantitatively but also qualitatively different responses. That is, high doses do not always produce effects similar to low doses but at greater intensity. Although the ability to disrupt sensory and cognitive functions is generally correlated to dose, a completely different experience of an “alternate reality” can sometimes occur, most often at high doses. This psychological state has often been referred to in the popular press as a “peak experience,” “transcendent,” or “mystical” experience and is a profoundly ASC. The user may feel transported to an alternate time or place, another dimension, or another plane of existence that may seem completely real. It is this experience that has been described as having parallels to the near death experience (NDE; Grof & Grof, 1980) and appears to have the most profound and long-lasting effects on the user. This state is of particular relevance to the definition of psychedelic and is emphasized in the term *entheogen* as noted earlier. Although this effect more often is achieved with high doses of hallucinogens, it can occur unpredictably and independently of the dose.

It is precisely this unpredictability of effect that can make clinical research with LSD and other hallucinogens so difficult. What criteria do one use to quantify drug effect? How does one establish baseline values? This unpredictability is no doubt also a primary factor in adverse reactions (“bad trips”) that occur with recreational use of these drugs. At the extremes, a user might on one occasion experience ecstasy and mystical union with the cosmos, while on another they might endure a hellish nightmare, extreme paranoia, feelings of insanity, and the like.

Although there is less written today about psychedelics, LSD experimentation has continued among high school youth over the past several decades. The Monitoring the Future Survey, conducted by the University of Michigan's Institute for Social Research and funded by the National Institute on Drug Abuse (NIDA), has tracked illicit drug use and attitudes toward drugs by high school youth since 1975.

Although hallucinogen use had remained relatively steady for decades, in 2002, use declined for 12th graders, with past year use also down among 10th graders. LSD, in particular, showed sharp declines in use among 8th, 10th, and 12th graders in 2002 compared with 2001. Rates of LSD use were the lowest in the history of the survey among students in all three grades (NIDA, 2002).

A major difference between present recreational usage and that of a decade or more ago seems to be that LSD dosages currently available on the clandestine market are typically in the 40–60 µg range rather than the 100–250 µg doses more characteristic of the 1960s and 1970s. At these lower dosages, the psychological effects of psychedelics are generally not overwhelming, with less likelihood of an adverse reaction that might require medical intervention and be brought to the attention of reporting agencies or the press.

Because hallucinogens do not produce the type of reinforcing effects that occur after use of substances such as cocaine or amphetamine, an interesting question that can be asked is: What is the motivation for continued use of hallucinogens, once an “experimentation” phase has ended? It must be kept in mind that hallucinogen use is generally not compulsive and long lasting and that these substances do not produce dependence. Their use is more often episodic, and most people do not continue to use hallucinogens on a long-term basis after some initial experimentation. Surveys have shown that hallucinogen use is most likely to occur in the late teens and into the early 20s but does not usually continue after users reach their late 20s (Chilcoat & Schutz, 1996). Chronic use of hallucinogens is unusual (Henderson, 1994; Chilcoat & Schutz, 1996). This use pattern is in distinct contrast to the compulsive abuse that is often seen with rewarding drugs such as amphetamines, cocaine, or the opiates, which produce craving.

When asked why they use hallucinogens, individuals who take doses with significant psychological effects often say that they use them for personal or spiritual development and increased understanding and self-discovery, that their use seems important to them, and that often they feel they gain important personal, religious, or philosophical insights. These sorts of perceptions might arise as a consequence of markedly affecting cognitive processing in the frontal cortex, the area of the brain where executive decisions and the assessment of significance occurs (Goldberg, 2001). This reasoning may explain why humans take psychedelics, although they do not have rewarding effects in animal models: the nature of the reinforcement in humans is primarily cognitive, from perceptions of greater awareness, increased understanding, or profound insights that would have no counterpart in lower species with a less developed frontal cortex.

#### 4. How do hallucinogens work?

The mechanism of action of hallucinogens has been sought ever since their modern rediscovery initially because

it was felt that understanding how they affect the brain would lead to insights into the nature of schizophrenia. Later, it became of interest to understand the neuronal targets that were involved because those brain substrates clearly had to be involved in processing sensory information and making executive decisions. More recently, the focus has again shifted to understanding certain similarities between the effects of hallucinogens and acute psychosis, especially as investigators have begun to examine more closely the role of glutamatergic pathways in cortical function.

##### 4.1. Historical relationship between serotonin and hallucinogen action

Following the isolation and identification of 5-HT, interest in its role as a neurotransmitter and its possible relevance to behavior was greatly stimulated by the virtually contemporaneous discovery of LSD and recognition that this potent psychoactive substance had the ability to interact with 5-HT systems. From a chemist's perspective, it was easy to recognize the tryptamine template within the ergoline framework of LSD and to appreciate that the much simpler molecule of 5-HT was built on the same molecular scaffold. Twarog and Page (see Twarog & Page, 1953; Twarog, 1988) first demonstrated the presence of 5-HT in brain extracts, and it was only 10 years after the discovery of LSD that Gaddum (1953) reported that LSD antagonized the effects of 5-HT in peripheral tissues. The following year, Gaddum and Hameed (1954) and Woolley and Shaw (1954a, 1954b) independently proposed that the potent psychoactive properties of LSD might derive from the blockade of 5-HT receptors in the CNS (although in 1956 they modified their hypothesis to include the possibility that LSD might also mimic the actions of 5-HT; Shaw & Woolley, 1956). At about that time, Udenfriend et al. (1955) had just developed sensitive assays for 5-HT and its metabolites in various biological tissues, an advance that ushered in an era of intense research on 5-HT.

The idea that the central effects of LSD could be attributed to the blockade of 5-HT receptors was short lived, however. A brominated derivative of LSD, 2-bromoLSD (BOL-148; BOL), a potent 5-HT antagonist in peripheral tissues (Woolley & Shaw, 1954a), was found to be essentially devoid of LSD-like psychopharmacology (Cerletti & Rothlin, 1955; Rothlin, 1957). Indeed, BOL could actually antagonize the effect of a subsequently administered dose of LSD (Ginzel & Mayer-Gross, 1956), although BOL does have some LSD-like effects at doses that are about 100 times higher than for LSD (Isbell et al., 1959). Further, although LSD-like activity was initially thought to be correlated with anti-5-HT activity (Cerletti & Rothlin, 1955), the morpholide analogue of LSD had less than 10% of the antagonist effect of LSD yet had almost 75% of the potency of LSD as a hallucinogen (Gogerty & Dille, 1957). In addition, a series of cycloalkyl monosubstituted



amides of lysergic acid had 5-HT antagonist potency in the rat intestine 30% greater than LSD itself yet lacked LSD-like behavioral effects (Votava et al., 1958).

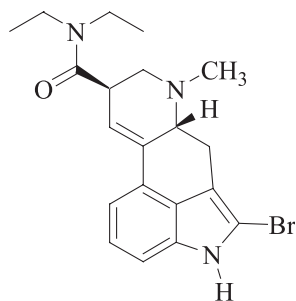

**BOL**

Nevertheless, it was evident that even if LSD was not a central antagonist of 5-HT, it did have effects on central serotonergic function. Freedman (1961) showed that systemic LSD administration elevated brain 5-HT content, an effect not shared by the nonhallucinogenic BOL or the behaviorally inactive *levo* isomer of LSD. Later, Rosecrans et al. (1967) reported that LSD also reduced brain levels of the 5-HT metabolite 5-hydroxyindole acetic acid (5-HIAA). Taken together, these findings demonstrated that LSD decreased 5-HT turnover in the brain.

Anden et al. (1968) were among the first to suggest that LSD might have a direct *agonist* effect at 5-HT receptors in the CNS. Within a few years, additional studies had been reported showing that the various classes of hallucinogens including psilocybin, DMT, 5-MeO-DMT, and the phenethylamine derivative 2,5-dimethoxy-4-methylamphetamine (DOM) all increased brain 5-HT levels and/or decreased the turnover of 5-HT (Freedman et al., 1970; Anden et al., 1971, 1974; Randic & Padjen, 1971; Fuxe et al., 1972; Leonard, 1973), phenomena that would be consistent with an agonist effect of these drugs.

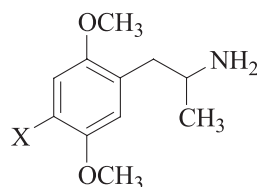

X = CH<sub>3</sub>; DOM  
X = Br; DOB  
X = I; DOI

#### 4.2. Early hypothesis for a presynaptic agonist mechanism of action

Early experiments showed that LSD was very potent in suppressing the firing of cells in the dorsal raphe nucleus,

either given systemically (Aghajanian et al., 1968, 1970) or applied directly by microiontophoresis to the raphe cell bodies (Aghajanian et al., 1972). The tryptamine hallucinogens DMT (Aghajanian et al., 1970), psilocin, and 5-MeO-DMT all inhibited dorsal raphe cell firing (Aghajanian & Haigler, 1975; deMontigny & Aghajanian, 1977), and Aghajanian and Haigler (1975) hypothesized that this suppressant effect on raphe cells might be the underlying basis for the action of hallucinogens. This idea was attractive because the raphe cells send serotonergic projections throughout the forebrain and are the source of 5-HT afferents in the prefrontal cortex (PFC; Moore et al., 1978).

Problems soon developed with this hypothesis, however, because the phenethylamine hallucinogens lacked this effect. For example, systemic administration of mescaline or DOM inhibited only about half of the dorsal raphe cells examined and had no effect or even slightly accelerated the rest (Aghajanian et al., 1970; Haigler & Aghajanian, 1973). Furthermore, the nonhallucinogenic ergoline, lisuride, also potently suppressed raphe cell firing (Rogawski & Aghajanian, 1979). In cat studies, suppression of raphe firing by hallucinogens outlasted the behavioral effects (Trulson et al., 1981). Much later, it was discovered that the suppression of raphe cell firing was mediated by stimulation of 5-HT<sub>1A</sub> somatodendritic receptors, and nonhallucinogenic 5-HT<sub>1A</sub> agonists were identified that suppressed raphe firing but which were not hallucinogenic (Sprouse & Aghajanian, 1987, 1988). This hypothesis for the mechanism of action of hallucinogens was, therefore, not tenable. Nevertheless, as discussed later, it seems possible that suppression of raphe cell activity may be important to the overall psychopharmacology of these substances because phenethylamines do suppress firing of a subset of raphe cells when given systemically but not when administered directly into the raphe (Aghajanian et al., 1970; Haigler & Aghajanian, 1973).

#### 4.3. Evidence for agonist activity at the serotonin<sub>2A</sub> receptor subtype

The vast majority of mechanistic studies on hallucinogens have been carried out in rodents. What little we know about the human pharmacology of hallucinogens mostly dates from about 40 to 50 years ago. Although a variety of animal behavioral paradigms have been employed over the years, the primary choice of an *in vivo* animal model today appears to be the two-lever drug discrimination procedure. In this paradigm, rats are trained to discriminate between the effects of saline and a training drug, typically LSD or a hallucinogenic amphetamine derivative such as DOM or DOI (Glennon et al., 1983a; Winter et al., 1999). Using various antagonists of the training drug effect, and substitution tests with compounds of known pharmacology, one is able to determine the underlying pharmacological basis for the training drug stimulus in the rat. This technique is very powerful and produces robust effects at relatively low drug

dosages that generally do not elicit other overt behaviors. In essence, the rat “tells” the experimenter, “I think you gave me the training drug” or “I do not think you gave me anything.” Although this type of yes/no result obviously cannot provide information about the qualitative aspects of intoxication that the drug might produce in man, at least it indicates whether the substance has overall pharmacological properties that resemble the training drug stimulus.

Table 1 gives a comparison of human dosages for several compounds where drug discrimination data in LSD-trained rats also have been obtained from the author’s laboratory. Although there are several other hallucinogens that have been characterized using the drug discrimination paradigm, particularly by Richard Glennon and his colleagues, different training drugs have been used. Affinities in cloned human 5-HT<sub>2A</sub> and 5-HT<sub>2C</sub> were also obtained for many of the compounds listed in the table at the same time in one study (Nelson et al., 1999). Although the relative potencies in rats and humans compared with LSD vary somewhat, it can be seen that there is overall good general agreement.

One cannot be certain that studies carried out with the drug discrimination paradigm actually reflect results that would be observed if similar experiments were carried out in humans, but the model has shown excellent correlation with the existing human data. A minor problem with the model is that it can produce false positives (i.e., give data predicting a compound to be hallucinogenic in man when it is known that the compound is not clinically active). Nevertheless, these are probably the best data available, and much of what we know about the in vivo mechanism of action of hallucinogens is based on drug discrimination studies in rats. The use of drug discrimination to study hallucinogens has been reviewed (Winter, 1994; Glennon, 1999; Winter et al., 1999).

The earliest hypothesis that hallucinogenic drugs acted specifically at 5-HT<sub>2</sub> receptor subtypes was proposed by Glennon et al. (1983c) based on drug discrimination studies in rats showing that the 5-HT<sub>2</sub> antagonists ketanserin and pirenperone blocked the discriminative stimulus effects of phenethylamine and tryptamine hallucinogens, including LSD (Colpaert et al., 1982; Leysen et al., 1982; Colpaert & Janssen, 1983). Earlier studies (Browne & Ho, 1975; Winter, 1975) had also shown that the discriminative stimulus of mescaline was blocked by 5-HT antagonists that later were recognized to block 5-HT<sub>2</sub> receptors.

Now, there seems to be a fairly clear consensus that the key site for hallucinogen action is the 5-HT<sub>2A</sub> receptor subtype (McKenna & Saavedra, 1987; Titeler et al., 1988; Pierce & Peroutka, 1989; Sadzot et al., 1989; Branchek et al., 1990; Nichols, 1997; Egan et al., 1998; Krebs-Thomson et al., 1998; Smith et al., 1998, 1999; Aghajanian & Marek, 1999a; Nelson et al., 1999; Scruggs et al., 2000; Ebersole et al., 2003). This conclusion was initially developed by correlation of the rat behavioral activity of hallucinogenic amphetamines with their affinities and efficacies at the 5-HT<sub>2</sub> receptor (Glennon et al., 1983c, 1984a, 1984b, 1986; Sanders-Bush et al., 1988).

Because all of the hallucinogens have nearly equal or in some cases even slightly higher potency at 5-HT<sub>2C</sub> than at 5-HT<sub>2A</sub> receptors, there had been some past uncertainty as to which of these receptor subtypes was more important to the mechanism of action. Although ketanserin, used as an antagonist in many studies, is clearly more selective for 5-HT<sub>2A</sub> sites, Ismaiel et al. (1993) have shown that a spiperone analogue with about 2000-fold selectivity for the rat 5-HT<sub>2A</sub> over the 5-HT<sub>2C</sub> receptor was able to block the discriminative cue of the hallucinogenic amphetamine DOM in the two-lever drug discrimination paradigm in rats.

Table 1

A comparison of human doses of selected hallucinogens with their potency using drug discrimination tests in LSD-trained rats

Drug	K <sub>i</sub> <sup>1</sup> 5-HT <sub>2A</sub> (nM)	K <sub>i</sub> <sup>1</sup> 5-HT <sub>2C</sub> (nM)	Drug discrimination ED50 <sup>2</sup> (μM/kg)	Potency relative to LSD (rat drug discrimination)	Human dose (mg) <sup>3</sup>	Potency relative to LSD (human)
EthLAD	–	–	0.02	185	0.04–0.15	140
AllyLAD	–	–	0.013	285	0.08–0.16	110
LSD	2–4	3–6	0.037	100	0.06–0.20	100
ProLAD	–	–	0.037	100	0.10–0.20	90
DOB	0.6	1.3	1.06	2.3	1–3	7
DOI	0.7	2.4	0.28	9.2	1.5–3	6
DOM	19	–	0.89	3.3	3–10	2
Psilocin	15–25	10	1.0	2.6	10–15	1
DMCPA	–	–	0.66	4.5	15–20	0.7
MEM	73	124	12	0.2	20–50	0.4
MMDA-2	–	–	7	0.4	25–50	0.4
Mescaline	550	300	34	0.08	200–400	0.04

Where available, K<sub>i</sub> values for cloned human 5-HT<sub>2A</sub> and 5-HT<sub>2C</sub> receptors are also listed for comparison. Compounds are ranked by relative human potency.

<sup>1</sup> Affinity of phenethylamines in cloned receptors taken from Nelson et al. (1999) and mescaline affinity from Monte et al. (1997).

<sup>2</sup> Drug discrimination data from Nichols et al. (1984a, 1984b, 1986, 1991b), Hoffman and Nichols (1985), Monte et al. (1997), and Blair et al. (2000).

<sup>3</sup> Averaged dose range from Shulgin and Shulgin (1991, 1997); LSD = 100. Abbreviations from Shulgin and Shulgin (1991, 1997): EthLAD, *N*-ethyl-*N*(6)-norLSD; AllyLAD, *N*-allyl-*N*(6)-norLSD; ProLAD, *N*-*n*-propyl-*N*(6)-norLSD; DMCPA, (±)-*trans*-2,5-dimethoxy-4-methylphenylcyclopropylamine; MEM, (±)-2,5-dimethoxy-4-ethoxyamphetamine; MMDA-2, (±)-2-methoxy-4,5-methylenedioxyamphetamine.

In addition, Schreiber et al. (1994) were able to abolish the discriminative cue of the hallucinogenic amphetamine derivative DOI in rats with the highly selective 5-HT<sub>2A</sub> receptor antagonist M100907 (Schmidt et al., 1992). This antagonist has greater than 200-fold selectivity for 5-HT<sub>2A</sub> versus 5-HT<sub>2C</sub> receptors. A selective 5-HT<sub>2C</sub> receptor antagonist SB 200,646 (Kennett et al., 1994) did not block the stimulus effect of DOI at doses that were effective in antagonizing behavioral effects caused by 5-HT<sub>2C</sub> receptor activation.

Fiorella et al. (1995a, 1995b, 1995c) have provided additional compelling evidence for 5-HT<sub>2A</sub> receptor mediation of the hallucinogen stimulus in rats using antagonist correlation analysis. The ability of a series of nonselective 5-HT<sub>2A/2C</sub> receptor antagonists to block the discriminative stimulus properties of (–)-DOM was linearly correlated with their affinity for 5-HT<sub>2A</sub> sites but not with 5-HT<sub>2C</sub> affinity.

Some caution must still be exercised in extrapolating rat drug discrimination data to humans. It is somewhat troubling that the 5-HT<sub>2</sub> antagonists ketanserin and pirenperone failed to block the LSD cue in drug discrimination studies with LSD-trained monkeys (Nielsen, 1985). Mescaline, another hallucinogenic 5-HT<sub>2A</sub> agonist, also failed to substitute for LSD in monkeys (Nielsen, 1985). Curiously, 5-MeO-DMT, a mixed 5-HT<sub>1A</sub>/5-HT<sub>2</sub> agonist (Martin & Sanders-Bush, 1982) did substitute. This latter finding raises the interesting possibility that the discriminative cue of LSD in monkeys may be mediated through the 5-HT<sub>1A</sub> rather than the 5-HT<sub>2A</sub> receptor. For example, in rats trained to discriminate 5-MeO-DMT (3 mg/kg) from saline, the 5-HT<sub>1A</sub> antagonists pindolol and WAY 100635 both produced significant antagonism of the training stimulus, whereas the 5-HT<sub>2</sub> antagonist pirenperone was much less effective (Winter et al., 2000b). Full generalization of the 5-MeO-DMT stimulus also occurred to the selective 5-HT<sub>1A</sub> agonist 8-OH-DPAT, which was blocked by WAY 100635 but unaffected by pirenperone. The data indicate that 5-MeO-DMT-induced stimulus control is mediated primarily by interactions with 5-HT<sub>1A</sub> receptors. A more thorough discussion of the possible importance of the 5-HT<sub>1A</sub> receptor is given in a later section of this review.

The head twitch in rats also appears to be mediated by an agonist action at 5-HT<sub>2A</sub> receptors. Schreiber et al. (1995) showed that head twitches induced by DOI were abolished by low doses of the 5-HT<sub>2A</sub>-selective antagonist M100907. The selective 5-HT<sub>2C</sub> antagonist, SB 200,646A failed to block DOI-induced head twitch. Hyperthermia and hypophagia induced in rats by either DOM or DOI are also mediated by the 5-HT<sub>2A</sub> receptor (Aulakh et al., 1994b; Mazzola-Pomietto et al., 1995). In addition, DOM administration to rats significantly elevates plasma prolactin, adrenocorticotrophic hormone (ACTH), and corticosterone (Aulakh et al., 1994a). The observed increases were blocked by various 5-HT<sub>2A/2C</sub> nonselective antagonists. The ACTH but not the prolactin and corticosterone re-

sponse was also blocked by spiperone, and the authors suggest that the increase in ACTH may be mediated by 5-HT<sub>2A</sub> receptors.

Further evidence for 5-HT<sub>2A</sub> mediation of the effects of hallucinogens also comes from studies of tolerance. A very rapid tolerance known as tachyphylaxis is produced on repeated administration of hallucinogens, and this phenomenon is now believed to occur as a result of 5-HT<sub>2A</sub> receptor down-regulation. Daily administration of LSD results in almost complete loss of sensitivity to the effects of the drug by the 4th day (Cholden et al., 1955; Isbell et al., 1956). Similarly, daily administration of the hallucinogenic amphetamine DOM to man also led, by the 3rd day, to significant tolerance to the drug effect (Angrist et al., 1974). In humans, cross-tolerance occurs between mescaline and LSD (Balestrieri & Fontanari, 1959) and between LSD and psilocybin (Isbell et al., 1961). Tolerance and cross-tolerance also develops to hallucinogens in rat and cat models (Freedman et al., 1958; Smythies et al., 1966; Appel & Freedman, 1968; Winter, 1971; Freedman & Boggan, 1974; Wallach et al., 1974; Trulson et al., 1977; Commisaris et al., 1980).

Several studies have now shown that rapid tolerance to hallucinogens correlates with down-regulation of the 5-HT<sub>2A</sub> receptor. For example, Buckholtz et al. (1985, 1990) found that daily LSD administration selectively decreased 5-HT<sub>2</sub> receptor density in rat brain. These workers also reported that not only LSD but also the hallucinogenic amphetamines DOB and DOI produced 5-HT<sub>2</sub> receptor down-regulation after repeated dosing in rats (Buckholtz et al., 1988). Chronic treatment of rats for 7 days with either DOB or DOI (Buckholtz et al., 1988) or DOI (McKenna et al., 1989a), respectively, produced down-regulation of brain 5-HT<sub>2</sub> receptors in rat.

Leysen et al. (1989) observed rapid desensitization and down-regulation of central 5-HT<sub>2</sub> receptors following repeated treatment of rats with DOM. A significant reduction in the total number of cortical 5-HT<sub>2</sub> sites was observed after only two drug treatments (2.5 mg/kg s.c. every 8 hr). After four injections in 24 hr, the receptor number recovered only very slowly ( $T_{1/2} = 5$  days). Smith et al. (1999) likewise found that tolerance to the discriminative stimulus effects of DOI in rats was correlated with down-regulation of 5-HT<sub>2A</sub> receptors but found no change in density of 5-HT<sub>2C</sub> receptors. Short-term agonist exposure also leads to desensitization of 5-HT<sub>2A</sub> receptor-mediated phosphoinositide (PI) hydrolysis in several transfected cell systems (Ivins & Molinoff, 1991; Roth et al., 1995; Gray et al., 2001). Interestingly, in contrast to most other G-protein-coupled receptors (GPCRs), the 5-HT<sub>2A</sub> receptor undergoes down-regulation in response to either agonist or antagonist treatment (Gray & Roth, 2001). Very recently, two nonconserved residues in the 5-HT<sub>2A</sub> receptor, S421 in the C terminus and S188 in intracellular loop 2, have been found to be essential to the agonist-induced desensitization process in cloned receptors expressed in HEK293 cells (Gray et al., 2003).

Mutation of either residue to alanine greatly attenuated 5-HT-mediated desensitization.

Although tolerance and down-regulation of 5-HT<sub>2A</sub> receptors occurs following repeated dosing with LSD or the hallucinogenic amphetamines DOM, DOB, or DOI, the tryptamine hallucinogen DMT appears to have somewhat different properties. DMT substituted fully in rats trained to discriminate DOI from ketanserin, indicating that it had discriminative stimulus properties mediated through the 5-HT<sub>2A</sub> receptor (Smith et al., 1998). In rat fibroblasts expressing the 5-HT<sub>2A</sub> receptor, DMT was a full agonist in stimulating PI hydrolysis; however, in cells transfected with the 5-HT<sub>2C</sub> receptor, DMT was only a partial agonist. Nevertheless, these workers found that the 5-HT<sub>2C</sub> but *not* the 5-HT<sub>2A</sub> receptor showed profound desensitization to DMT over time. Although these findings were unexpected, Strassman et al. (1996) have shown that in humans repeated dosing with DMT did not lead to tolerance. Therefore, if 5-HT<sub>2C</sub> desensitization is also occurring in humans in response to repeated DMT administration, the failure to observe tolerance to the behavioral effects would be consistent with a 5-HT<sub>2A</sub>-mediated mechanism of action.

Circumstantial evidence that the effects of hallucinogens are primarily mediated by 5-HT<sub>2A</sub> receptors includes the fact that in the cortex, where hallucinogens are thought to act, 5-HT<sub>2A</sub> receptors markedly predominate over 5-HT<sub>2C</sub> receptors (Pompeiano et al., 1994; Wright et al., 1995). Further, the EC<sub>50</sub> of LSD for activating 5-HT<sub>2A</sub> receptors (Kurrasch-Orbaugh et al., 2003b) is virtually identical to the peak plasma levels of LSD (10–20 nM) measured after either i.v. or p.o. administration (Aghajanian & Bing, 1964; Hawks & Chiang, 1986).

The issue is confounded, however, by the fact that LSD is a very weak partial agonist (Pierce & Peroutka, 1988; Sanders-Bush et al., 1988; McClue et al., 1989; Kurrasch-Orbaugh et al., 2003b) or even an antagonist (Norman et al., 1989; Pierce & Peroutka, 1990) at the 5-HT<sub>2A</sub> receptor. Electrophysiological studies of layer II pyramidal cells in piriform cortex have shown that activation of 5-HT<sub>2A</sub> receptors increased spontaneous inhibitory postsynaptic potentials (IPSPs) through activation of  $\gamma$ -aminobutyric acid (GABA)ergic layer III interneurons (Sheldon & Aghajanian, 1990; Gellman & Aghajanian, 1994). Subsequently, Marek and Aghajanian (1996c) found that both LSD and DOI, at physiologically relevant concentrations, induced concentration-dependent increases in the firing rate of these interneurons. Nonetheless, the maximal effect produced by these drugs was only 30–50% of that obtained with 5-HT, and neither LSD nor DOI produced significant antagonism of the 5-HT response. These studies did, however, provide evidence for the hypothesis that hallucinogens are potent partial agonists rather than antagonists.

The most compelling evidence that hallucinogens have agonist activity at 5-HT<sub>2A</sub> receptors was obtained from two

clinical studies. The first study was not definitive, however, where the mixed 5-HT<sub>2A/2C</sub> antagonist cyproheptadine antagonized the subjective effects of DMT in some subjects (Meltzer et al., 1982). The more important and most recent example is the report by Vollenweider et al. (1998) where the relatively 5-HT<sub>2A</sub>-selective antagonists ketanserin and ritanserin blocked the hallucinogenic effects of psilocybin as quantified using the APZ-OAV subscales of Dittrich's ASC questionnaire (Dittrich, 1998). Three groups of subjects were used, with one group receiving either 20 or 40 mg of ketanserin p.o., a 2nd group receiving 0.5 or 1.0 mg of the 5-HT<sub>2A/D2</sub>-selective antagonist risperidone p.o., and the 3rd group receiving haloperidol 0.021 mg i.v. Each group also included a placebo treatment. Psilocybin (0.25 mg/kg) was given p.o. 75 min following pretreatment. Ketanserin (20 mg) significantly reduced the psilocybin-induced increase in the APZ-OAV score by 50–70%, and the 40 mg dose completely prevented the development of psilocybin effects in 4 of 5 subjects tested. Risperidone had similar effects, with the 0.5 mg dose significantly attenuating scores by 69–78% and the 1.0 mg dose completely blocking psilocybin effects. Although risperidone also has high affinity for DA D<sub>2</sub> receptors, the potent D<sub>2</sub> antagonist haloperidol produced a significant reduction on only one subscale of the instrument and had no effect on visual illusions or hallucinations.

Psilocybin also increased reaction time on a memory-guided delayed response task (DRT) given at the peak drug effect and both ketanserin and ritanserin but not haloperidol blocked the increase in reaction time. A second experiment was then undertaken to confirm these results where a group of 10 subjects was given 40 mg of ketanserin p.o. followed by psilocybin. A statistically significant block (87–96%) of psilocybin-induced scores on all the APZ-OAV measures was obtained.

Something seldom discussed in the hallucinogen literature is the fact that the affinity of LSD for the 5-HT<sub>2A</sub> receptor is unremarkable and is comparable with that of hallucinogenic amphetamines such as DOB and DOI that are 20–30 times less potent *in vivo* either in man or in rats. If PI hydrolysis is considered as a marker for receptor activation, LSD has intrinsic activity of perhaps only 20–25% compared with 5-HT (100%), whereas typical hallucinogenic amphetamines or mescaline are nearly full agonists (Monte et al., 1997; Kurrasch-Orbaugh et al., 2003b). Even when the release of arachidonic acid (AA) is examined as the signal arising from 5-HT<sub>2A</sub> activation, LSD is a weak agonist (ca. 50%) compared with behaviorally much less potent compounds (Kurrasch-Orbaugh et al., 2003b). There is no evidence to suggest that pharmacokinetic or metabolic factors can account for this discrepancy. Thus, later in this review, two possibilities will be considered. Either that LSD may activate another receptor that is synergistic with 5-HT<sub>2A</sub> receptor activation or the 5-HT<sub>2A</sub> receptor may be coupled to another signaling pathway that has not yet been identified.



#### 4.3.1. Relevance of animal models to man: species differences in receptors

Although the interoceptive cue produced by hallucinogens in rats appears to be mediated by 5-HT<sub>2A</sub> receptor stimulation, the hypothesis that this effect also mediates hallucinogen intoxication in humans was confounded by the fact that the rat and human 5-HT<sub>2A</sub> receptor subtypes have somewhat different structure-activity relationships apparently based on a single amino acid substitution in transmembrane region V (see discussion below). Hence, effects of various hallucinogens on rat behavior may not strictly parallel those in humans.

Kao et al. (1992) first showed that residue 242 in TM V, which is serine in the human but alanine in the rat 5-HT<sub>2A</sub> receptor, could explain different binding affinities of these two receptors for mesulergine, an *N*-methylated ergoline 5-HT<sub>2C</sub> antagonist ligand. Mutation of Ser<sup>242</sup> in the human receptor to Ala gave a mutant receptor with binding characteristics similar to the rat wild type.

Following a similar line of inquiry, Nelson et al. (1993) and Johnson et al. (1994) have shown that differential affinities of ergolines and their *N*(1)-alkyl derivatives for the rat and human 5-HT<sub>2A</sub> receptors can be attributed to the difference in this same amino acid. Ergoline and tryptamine ligands had higher affinity for the human receptor (Ser<sup>242</sup>), whereas *N*(1)-alkylated ergolines and tryptamines had higher affinity for the rat receptor (Ala<sup>242</sup>). Johnson et al. also prepared the mutant rat receptor Ala<sup>242</sup>→Ser<sup>242</sup>, complementing the work of Kao et al. (1992), and showed that this converted the rat receptor into one having binding characteristics virtually identical to the human receptor. These workers speculated that the serine in the human receptor serves as a hydrogen bond acceptor for the indole NH, whereas in the rat receptor, the alanine residue interacts with the *N*-alkyl group of the alkylated ergolines.

Gallaher et al. (1993) found that the human 5-HT<sub>2A</sub> receptor had 15-fold higher affinity for psilocin than the rat receptor and speculated that Ser<sup>242</sup> in the human receptor might hydrogen bond to the 4-hydroxy of psilocin, leading to a binding orientation where the indole ring was rotated 180° from its orientation in that of DMT, 5-HT, or bufotenin (5-hydroxy-DMT). These studies emphasize the probability that this residue is part of the ligand recognition site in the 5-HT<sub>2A</sub> receptor and also point out that the binding orientations of ligands with only subtle structural differences (i.e., 4- vs. 5-hydroxy) may differ dramatically and may not be intuitively obvious. Clearly, this observation lends some uncertainty to the generalization of rat data to the human situation.

Over the past several years, there have been several studies of the molecular biology of the 5-HT<sub>2A</sub> receptor. Although hypothetical binding orientations and amino acids that are determinants of binding have been studied through mutagenesis experiments, it is beyond the scope of this review to summarize that work. The interested reader can consult the following references and reviews for

further information about those studies (Weinstein et al., 1988, 1994; Gallaher et al., 1993; Johnson et al., 1993, 1994, 1997; Wang et al., 1993; Shih et al., 1994; Sealton et al., 1995; Almaula et al., 1996a, 1996b; Roth et al., 1997b, 1998; Shapiro et al., 2000, 2002; Chambers & Nichols, 2002; Ebersole & Sealton, 2002; Ebersole et al., 2003).

#### 4.3.2. Signaling through the serotonin<sub>2A</sub> receptor: agonist trafficking

The 5-HT<sub>2A</sub> receptor is a member of the superfamily of GPCRs that couple to heterotrimeric GTP binding proteins. The most prominent and well-understood signaling mediated by the 5-HT<sub>2A</sub> receptor is coupling to G<sub>αq</sub>, resulting in stimulation of PI-specific phospholipase C (PLC; Conn & Sanders-Bush, 1984; Roth et al., 1984). PLC hydrolyzes phosphatidylinositol membrane lipids at the *sn*-3 position, generating inositol-1,4,5-triphosphate (IP<sub>3</sub>) and diacyl glycerol (DAG; Conn & Sanders-Bush, 1986; Williams, 1999). The inositol phosphates lead to release of Ca<sup>2+</sup> from intracellular stores. DAG remains bound to the membrane and activates protein kinase C (PKC). These 2nd messenger systems ultimately mediate, in part, the cellular physiological response to receptor activation.

It has been generally assumed that this PI hydrolysis signaling pathway is the most relevant for the action of hallucinogens, but there are certain problems with this hypothesis. First and foremost, it is well known that LSD has very low efficacy in activating PI turnover (Sanders-Bush et al., 1988; Egan et al., 1998). Recently, Rabin et al. (2002) noted a lack of correlation between behavioral potency in drug substitution in rats trained to discriminate LSD or DOM from saline and efficacy in stimulating PI hydrolysis. They concluded that 5-HT<sub>2A</sub>-mediated stimulation of PI hydrolysis does not appear to be the sole critical signaling mechanism involved in the discriminative effects of hallucinogens. Similarly, Roth et al. (1997a) found that there was no significant relationship between high-affinity agonist binding and ability to stimulate PI turnover, and these investigators proposed that additional transition states of the receptor-ligand complex must be essential for agonist efficacy.

The activation of 5-HT<sub>2A</sub> receptors also leads to stimulation of phospholipase A<sub>2</sub> (PLA<sub>2</sub>), which preferentially hydrolyzes AA-containing phospholipids at the *sn*-2 position to produce free AA and lysophospholipid. The PLA<sub>2</sub> pathway is completely independent of PLC-mediated signaling (Berg et al., 1998b; Kurrasch-Orbaugh et al., 2003b). This signaling pathway has been demonstrated in hippocampal slices (Felder et al., 1990) and in cellular systems (Berg et al., 1994; Tournois et al., 1998). The PLA<sub>2</sub> signaling pathway is a great deal more complex than the PI turnover cascade, however, apparently involving multiple G-proteins and the ERK1,2 and p38 mitogen-activated protein kinases at least in NIH3T3 cells (Kurrasch-Orbaugh et al., 2003a).

Although the significance of this pathway has not been investigated in detail, Qu et al. (2003) showed that administration of 2.5 mg/kg DOI to rats led to significantly increased incorporation of [ $^3$ H]AA in brain. Using quantitative autoradiography, these workers found large increases in labeled AA incorporation particularly in the neocortex. The largest increases were seen in brain regions having high densities of 5-HT<sub>2A</sub> receptors compared with 5-HT<sub>2C</sub> sites.

Clearly, specific hallucinogen ligands interact with the 5-HT<sub>2A</sub> receptor to activate the PLC and PLA<sub>2</sub> pathways to different extents. In the rat 5-HT<sub>2A</sub> receptor expressed in NIH3T3 cells, LSD, DOB, psilocin, and 5-MeO-DMT have different EC<sub>50</sub> values and intrinsic activities in activating the AA and PI turnover pathways. Table 2 shows these relative agonist effects, and there are clearly great differences in the ability of a specific ligand differentially to activate one of these signaling pathways (Kurrasch-Orbaugh et al., 2003b). It may be noted that nearly all of the compounds examined had greater potency in inducing AA release than in stimulating PI turnover. Although the exception was LSD, this molecule did have greater intrinsic activity in the AA pathway. Some of these differences are very noteworthy (e.g., psilocin), where the potency (EC<sub>50</sub>) for activating AA release was nearly 30-fold greater than for stimulating PI turnover.

Furthermore, Kurrasch-Orbaugh et al. (2003b) also demonstrated that the two signaling pathways have different receptor reserves. That is, activation of a much smaller fraction of 5-HT<sub>2A</sub> receptors is required for stimulation of the PLA<sub>2</sub> pathway compared with PLC activation, emphasizing the potential importance of AA mobilization via the 5-HT<sub>2A</sub> receptor. These findings are consistent with those of Rabin et al. (2002), as noted earlier, who also questioned the relevance of the PI signaling pathway in the action of hallucinogens. Therefore, if one of these two signaling pathways is most relevant to the actions of hallucinogens, one might conclude that the activation of PLA<sub>2</sub> is more important. Nevertheless, as a group, psychoactive versus nonpsychoactive agonists did not differ in their ability to activate selectively 5-HT<sub>2A</sub> receptor-mediated PLA<sub>2</sub> or PLC signaling.

For many GPCRs, it is now known that certain ligand molecules may possess activities ranging in the extreme

from full intrinsic activity agonist to silent antagonist at an identical receptor isoform apparently depending only on its cellular localization (Kilts et al., 2002; Mottola et al., 2002). Furthermore, agonists may vary in their intrinsic activity at different signaling pathways. This phenomenon has been called “functional selectivity,” and in other laboratories, the effect has been called “agonist-directed trafficking” (Berg et al., 1998a, 1998b; Akin et al., 2002; Brink, 2002; Cussac et al., 2002) or “differential engagement of G-proteins” (Manning, 2002). Thus, in all GPCR systems, conclusions about the importance of specific intracellular signaling pathways may be confounded by uncertainties about which G-proteins are actually engaged by the receptor following activation by a particular ligand.

To complicate matters even further, it very recently has been shown that the 5-HT<sub>2A</sub> receptor can also couple to phospholipase D (PLD; Mitchell et al., 1998; Robertson et al., 2003). This enzyme principally catalyzes the hydrolysis of the terminal diester bond of phosphatidyl choline, generating phosphatidic acid and choline. It can also catalyze a phosphatidyl transfer reaction in which a primary alcohol is the nucleophile instead of water (“transphosphatidylation”), and this latter reaction is the basis for quantifying the action of PLD (for recent review, see Gomez-Cambronero & Keire, 1998). Although PLD activation has been found to be dependent on ADP-ribosylation factor 1 (ARF1; Robertson et al., 2003), it remains unknown which G-protein(s) actually mediate this signal. For the 5-HT<sub>2C</sub> receptor, a related GPCR of the 5-HT<sub>2</sub> family, McGrew et al. (2002) have provided evidence that PLD activation is mediated through a G<sub>13</sub> protein. Furthermore, in the latter study, 5-HT produced signals of equal magnitude in both PLC and PLD pathways. These findings add a whole new level of complexity to the issue of agonist trafficking because to date no one has studied the effects of hallucinogens in activating the PLD signaling pathway. Thus, it remains entirely possible that effects in this signaling pathway might be highly relevant to the mechanism of action.

It should be noted that Acuna-Castillo et al. (2002) have recently reported that substituted amphetamine hallucinogens such as DOB and DOI are partial agonists (ca. 50% intrinsic activity), and their corresponding phenethylamine-type 5-HT<sub>2A</sub> ligands are *antagonists* at cloned rat 5-HT<sub>2A</sub> receptors expressed in *Xenopus laevis* oocytes, where the

Table 2  
Ability of several 5-HT<sub>2A</sub> ligands differentially to activate signaling pathways through the rat 5-HT<sub>2A</sub> receptor expressed in NIH3T3 cells

Drug	[ $^{125}$ I]DOI	PLA <sub>2</sub> -AA release		PLC-IP accumulation	
	K <sub>i</sub> (nM)	EC <sub>50</sub> (nM)	Intrinsic activity (%5-HT)	EC <sub>50</sub> (nM)	Intrinsic activity (%5-HT)
5-HT	21 (2.8)	83 (7.2)	100	120 (6.9)	100
d-LSD	3.5 (0.62)	20 (3.8)	56 (9.4)	9.8 (3.7)	22 (2.6)
Lisuride	7.2 (0.33)	13 (3.9)	32 (7.9)	41 (15)	13 (3.7)
DOB	4.3 (0.28)	15 (4.8)	75 (6.3)	72 (3.6)	79 (6.0)
5-MeO-DMT	42 (9.9)	190 (31)	70 (10)	2400 (890)	99 (8.5)
Psilocin	25 (4.7)	86 (3.9)	42 (5.7)	2300 (290)	46 (2.4)

Adapted from Kurrasch-Orbaugh et al. (2003b).

measured response was 5-HT-induced currents in the oocyte membrane. This conclusion runs counter to the preponderance of evidence from other studies, discussed above, at least for the phenethylamine type hallucinogens. For example, in drug discrimination studies, Glennon et al. (1988) found that the phenethylamine hallucinogen 2,5-dimethoxy-4-bromophenethylamine (2C-B) substituted for DOM, a hallucinogenic amphetamine with agonist effects in behavioral assays (Ismail et al., 1993). Because both DOB and DOI possess 5-HT<sub>2A</sub> agonist activity in a variety of assays (Owens et al., 1991a, 1991b; Willins & Meltzer, 1997; Shapiro et al., 2000), it would be somewhat surprising if simply removing the  $\alpha$ -methyl group converted them into antagonists. Indeed, the prototypical phenethylamine mescaline is a high intrinsic activity agonist at the 5-HT<sub>2A</sub> receptor (Monte et al., 1997). Further, both DOI and its 4-trifluoromethyl congener (DOTFM) were nearly full agonists in stimulating PI turnover through the 5-HT<sub>2A</sub> receptor expressed in NIH-3T3 cells (Nichols et al., 1994). Removing the  $\alpha$ -methyl of DOTFM gave a 2-carbon homologue that still retained nearly 60% intrinsic activity in these cells. In addition, both this analogue and the 2-carbon phenethylamine homologue of DOI gave full substitution in the drug discrimination assay in rats trained to discriminate LSD from saline.

Clear interpretation of this issue is complicated by the phenomenon of agonist-directed trafficking as discussed above. Thus, the unexpected finding by Acuna-Castillo et al. (2002) that hallucinogenic phenethylamines are *antagonists* at the 5-HT<sub>2A</sub> receptor expressed in an *oocyte* system must be considered tentative until more is known about the signaling pathways and G-protein coupling that occur in oocytes compared with human neurons and the relative importance of PLA<sub>2</sub>, PLC, and PLD in 5-HT<sub>2A</sub> receptor signaling by hallucinogens.

One important question remains that is still not answered: Why is LSD so potent *in vivo*? As seen in Table 2, LSD has neither receptor affinity nor intrinsic activity at either of the currently known signaling pathways that would be consistent with its high *in vivo* potency. One possible explanation is that the interaction of LSD with other monoamine receptors is synergistic with its 5-HT<sub>2A</sub> receptor activation. Another explanation could be that there is an as yet undiscovered signaling pathway coupled to the 5-HT<sub>2A</sub> receptor, where the potency of LSD is more consistent with its *in vivo* potency. This suggestion is not so improbable when one considers the fact that there is not a single published study on the effects of hallucinogens on the PLD pathway.

#### 4.3.3. Neuroanatomical localization of serotonin<sub>2A</sub> receptors

The earliest studies to map 5-HT<sub>2</sub> binding sites in rat brain used autoradiography with several different tritiated antagonist ligands to identify brain areas with high receptor density (Pazos et al., 1985). Highest binding was observed

in the claustrum, with very high labeling in all areas and laminae of the neocortex. The highest binding density within the cortex was localized to a continuous band that included lamina IV and extending into lamina III depending on the area studied. A positron emission tomography (PET) study in humans using *N*1-[<sup>11</sup>C]-methyl-2-bromoLSD found highest binding in the frontal and temporal cortices, with lower levels in the parietal cortex and motor regions, intermediate levels in basal ganglia, but only very low levels in thalamus (Wong et al., 1987).

The finding of high-density 5-HT<sub>2</sub> binding sites in neocortex, later specifically identified as 5-HT<sub>2A</sub> receptors, is characteristic of virtually all of the subsequent localization studies. Pazos et al. (1987) examined anatomical distribution of 5-HT<sub>2</sub> receptors in human brain with light microscopic autoradiography using the 5-HT<sub>2A</sub> antagonist ligand [<sup>3</sup>H]ketanserin. They observed a heterogeneous distribution of 5-HT<sub>2</sub> receptor densities with very high concentrations localized over layers III and V of several cortical areas, including the frontal, parietal, temporal, and occipital lobes, the anterogenual cortex, and the entorhinal area. These findings are consistent with the observation of a dense band of 5-HT<sub>2</sub> receptors in upper layer V in register with a dense plexus of fine 5-HT axons (Blue et al., 1988).

The hallucinogenic amphetamine agonist *R*-(-)-[<sup>125</sup>I]-DOI has also been used for autoradiography in rat brain. Brain areas with highest binding were the claustrum and the frontal cortex (McKenna & Saavedra, 1987). Lesser amounts were seen in the caudate, nucleus accumbens, and olfactory tubercle. The advantage of using a hallucinogenic amphetamine such as DOI is the relative pharmacological specificity for binding only at 5-HT<sub>2A/2C</sub> receptors. Although [<sup>3</sup>H]LSD has been used for autoradiography, it binds with high affinity to many types of CNS receptors (Diab et al., 1971; Gatzke, 1977; Meibach et al., 1980; Palacios et al., 1983). In the study by McKenna and Saavedra (1987), (+)-[<sup>125</sup>I]-2-iodoLSD was also used, which had high binding in the cortex as well as in several other brain regions, including areas rich in DA receptors. Their results were consistent with prior studies that also employed [<sup>125</sup>I]-2-iodoLSD (Engel et al., 1984; Nakada et al., 1984). Other autoradiographic and *in situ* hybridization studies have observed high densities of 5-HT<sub>2A</sub> receptors and transcripts in the cortex (Roth et al., 1987; Blue et al., 1988; Mengod et al., 1990; Wright et al., 1995), and a mRNA *in situ* hybridization study of human cortex demonstrated the 5-HT<sub>2A</sub> receptor on both pyramidal and non-pyramidal cells (Burnet et al., 1995). The 5-HT<sub>2A</sub> receptor is also expressed in the thalamus, primarily in sensory and “nonspecific” nuclei rather than in motor nuclei (Cornea-Hebert et al., 1999).

In a study by Seguela et al. (1989), it was found that cortical synaptic 5-HT terminals always made asymmetrical junctions, which were exclusively located on dendritic spines and shafts, appearing more frequently on spines in



the deep frontal and the upper occipital cortex. These workers found that cortical 5-HT innervation was predominantly (~60%) nonjunctional throughout the neocortex of the adult rat.

Willins et al. (1997) studied the regional and subcellular distribution of 5-HT<sub>2A</sub> receptor-like immunoreactivity in rat cortex using three different 5-HT<sub>2A</sub> receptor antibodies. These workers reported dense labeling of apical dendrites of pyramidal cells, with most of the 5-HT<sub>2A</sub>-like immunoreactivity associated with the plasma membrane. A small amount of labeling was seen on cortical interneurons.

Higher-resolution localization studies of the 5-HT<sub>2A</sub> receptor in primate brain (*Macaca mulatta*) using light and electron microscopic immunocytochemical techniques with a monoclonal antibody (PharMingen) were reported by Jakab and Goldman-Rakic (1998). In this study, immunoreactivity was seen throughout the cortical sheet, with weak staining in layer IV, but flanked by two intensely labeled bands in layers II and III and layers V and VI. It appeared to those workers that perhaps all pyramidal cells expressed the 5-HT<sub>2A</sub> receptor, with the label consistently found on the apical dendrites, most intensely in the proximal part of the dendrite. Dendritic spines were rarely or weakly labeled, a finding consistent with earlier studies in rat and monkey PFC (Hamada et al., 1998; Cornea-Hebert et al., 1999) but somewhat at odds with the report of Seguela et al. (1989).

In addition, Jakab and Goldman-Rakic (1998) identified presynaptic 5-HT<sub>2A</sub> receptors in a minor group of asymmetric synapse-forming cortical axons and suggested that 5-HT<sub>2A</sub> receptors might presynaptically modulate excitatory neurotransmission in a discrete cortical axonal system. In cortical interneurons, receptors were expressed on large and medium-sized interneurons, whereas there was no labeling on many small and medium-sized interneurons. Curiously, electron microscopic analysis showed the presence of the 5-HT<sub>2A</sub> label primarily in the cytoplasm of both pyramidal and nonpyramidal neurons, in stark contrast to the study by Willins et al. (1997) who found the receptor primarily associated with the plasma membrane.

These divergent results can be explained, however, by the type of antibody used for the immunocytochemistry. Nocjar et al. (2002), studying 5-HT<sub>2A</sub> receptor localization on DA cells in the ventral tegmental area (VTA), clearly showed that the polyclonal 5-HT<sub>2A</sub> receptor antibody strongly labeled both intracellular and membrane receptors, whereas the PharMingen monoclonal antibody used by Jakab and Goldman-Rakic (1998) labeled primarily intracellular receptors. These findings were consistent with their earlier report (Willins et al., 1997) and were also confirmed by a later study by Miner et al. (2003) as discussed below.

The most recent study of 5-HT<sub>2A</sub> receptor localization in rat cortex is that by Miner et al. (2003) who employed immunoperoxidase labeling to determine the localization of 5-HT<sub>2A</sub> receptors in the middle layers of the rat PFC. In this study, a polyclonal antibody was used as well as the same PharMingen monoclonal antibody employed by Jakab and

Goldman-Rakic (1998). Most 5-HT<sub>2A</sub> receptors were located within postsynaptic structures, predominantly on proximal and distal dendritic shafts, apparently on both pyramidal and local circuit neurons. Most commonly, 5-HT<sub>2A</sub> receptors were restricted to a particular area of the dendrite, usually extrasynaptic regions apposed to unlabeled dendrites. Of the immunopositive sites, 73% were postsynaptic, of which 58% of these were on dendritic shafts and 42% were present in dendritic spines. In this study, the degree of spine labeling was dependent on the primary antibody used for immunolabeling. In particular, the PharMingen monoclonal antibody failed to label a significant number of dendritic spines that could be identified with the polyclonal antibody, a result that confirms the earlier report of Nocjar et al. (2002) who found that the PharMingen monoclonal antibody failed to label membrane-bound receptors. This study provided the first evidence of extensive localization of 5-HT<sub>2A</sub> receptors to the heads and necks of dendritic spines. These results are consistent with those of Seguela et al. (1989) who found that synaptic 5-HT terminals always made asymmetric junctions that were exclusively found on dendritic spines and shafts and appeared more frequently on spines than shafts in the deep frontal and the upper occipital cortex. This postsynaptic localization is also consistent with the recent report by Xia et al. (2003) who showed that 5-HT<sub>2A</sub> receptors interact with postsynaptic density (PSD)-95, the major protein of PSD in asymmetric synapses.

Miner et al. (2003) emphasized their finding of a significant fraction of 5-HT<sub>2A</sub> receptors localized to extrasynaptic portions of dendritic shafts, suggesting that 5-HT within the PFC may exhibit at least a portion of its actions through volume transmission mechanisms (see, e.g., Agnati et al., 1995; Zoli et al., 1998). This hypothesis is consistent with findings from other immunocytochemical studies, where 5-HT<sub>2A</sub> receptor labeling was located some distance from 5-HT terminals in other regions of rat cortex (Jansson et al., 2001). Seguela et al. (1989) estimated that only about 38% of 5-HT axons in cortex engaged in synaptic contact. In addition, in four different cortical areas, dendritic shafts and spines and other axonal varicosities were often seen in the immediate microenvironment of immunostained varicosities. Furthermore, 5-HT reuptake transporters are frequently situated at extrasynaptic sites in PFC (Miner et al., 2000). Based on their results and previous data, Miner et al. suggested that cortical 5-HT innervation is primarily non-junctional and that the entire cortical volume may be within reach of this neurotransmitter. They propose that some of the physiological actions of 5-HT in cortex may be constantly exerted, with more or less efficacy at the various 5-HT receptors, providing widespread, global, and/or sustained influence in the neocortex.

Miner et al. (2003) found little evidence for significant presynaptic 5-HT<sub>2A</sub> receptor localization and identified only a few axons forming asymmetric synapses with weak immunoreactivity. Their findings, as well as prior studies that had also failed to identify significant numbers of 5-



HT<sub>2A</sub> receptors on axon terminals with characteristics of glutamate terminals, prompted these workers to conclude that their results were not consistent with the hypothesis that 5-HT<sub>2A</sub> receptors act as heteroreceptors on mediodorsal thalamic glutamate terminals in the middle layers of the rat PFC (Aghajanian & Marek, 1997, 1999b; Marek & Aghajanian, 1998a).

Nevertheless, Miner et al. (2003) did identify a significant fraction (24%) of 5-HT<sub>2A</sub> receptor-immunoreactive profiles that were presynaptic. These structures were thin and unmyelinated, rarely formed synaptic contacts in single sections, and sometimes contained dense-core vesicles, suggesting that they might be monoaminergic axons. They note that these might include DA fibers, consistent with reports that 5-HT<sub>2A</sub> receptors can modulate cortical DA function (Pehek et al., 2001).

The finding that 5-HT<sub>2A</sub> receptors are localized on cortical pyramidal cells is consistent with electrophysiological data suggesting that hallucinogens have excitatory effects on projection neurons in the neocortex (Araneda & Andrade, 1991; Ashby et al., 1994). Further, microiontophoresis of 5-HT in “hot spots” near the border of layers I/II and IV/Va induces increases in excitatory postsynaptic current (EPSC) frequency in layer V pyramidal cells (Aghajanian & Marek, 1997), where there is dense 5-HT<sub>2A</sub> receptor binding. This finding is consistent with the hypothesis that the most potent 5-HT<sub>2A</sub> receptor-mediated cortical actions of hallucinogens occur at hot spots on proximal apical dendritic shafts.

The thalamus may be the second most important site of action for hallucinogens. In rat brain, significant levels of 5-HT<sub>2A</sub> receptor mRNA have been found in the reticular nucleus, lateral geniculate nucleus, zona incerta, and anterodorsal and ventromedial nuclei of the thalamus (Cyr et al., 2000). Pompeiano et al. (1994) also found 5-HT<sub>2A</sub> mRNA in the reticular nucleus, lateral geniculate, and zona incerta but none in the midline or intralaminar nuclei. As discussed later, the thalamus, along with the amygdala, represents the major source of glutamate afferents innervating the neocortex. The thalamus not only processes somatosensory inputs but also receives afferents from both the raphe nuclei and the locus coeruleus (LC; Asanuma, 1992).

The reticular nucleus is of particular interest here because it is thought to serve as a sort of gate for processing signals to the cortex. Synaptic inputs to the reticular nucleus arise from the other thalamic nuclei, and it sends inhibitory projections back into the thalamus, apparently serving a negative-feedback regulatory role in thalamic function. It has been proposed to serve as a sort of “searchlight” of attention (Crick, 1984; Sherman & Guillery, 1996) and to control elements of signal-to-noise or the quality of information being sent to the cortex (see Vollenweider & Geyer, 2001, and references therein).

It is probably worth noting here that two PET studies (discussed in more detail later) have been reported that employed [<sup>18</sup>F]fluorodeoxyglucose (FDG) in subjects given

an effective dose of psilocybin. In one of the reports, FDG uptake was not significantly altered in the thalamus (Vollenweider et al., 1997b). In the 2nd study, however, metabolic activity was significantly *decreased* in the right thalamus and the left precentral region of the thalamus, with a nonsignificant decrease also observed in the left thalamus (Gouzoulis-Mayfrank et al., 1999). The latter study would lead one to speculate that attenuated thalamic metabolic activity reflects decreased firing in thalamocortical afferents carrying sensory information to the cortex. Although no work has appeared specifically directed to effects of hallucinogens within the thalamus, and particularly the reticular nucleus, the occurrence of mRNA for the 5-HT<sub>2A</sub> receptor as well as the crucial importance of the thalamus and thalamocortical interactions to consciousness are arguments that provide a significant rationale for future effort to be directed toward a more detailed examination of the role of the thalamus in the actions of hallucinogens.

Although the majority of studies point to a site of action for hallucinogens in the frontal cortex, with important involvement of the thalamus, there is also evidence of a role for the LC. This possibility is very intriguing because the LC is a point of convergence for widely ranging somatosensory and visceral sensory inputs from all regions of the body. The LC has been likened to a “novelty detector” for salient external stimuli (Cedarbaum & Aghajanian, 1978; Aston-Jones & Bloom, 1981). The LC sends norepinephrine (NE) projections diffusely to all parts of the neuraxis, including the cerebral cortex (Aghajanian & Marek, 1999a). Within the cortex, 5-HT<sub>2A</sub> and  $\alpha_1$ -adrenergic receptors share a similar regional and laminar distribution, with heaviest concentrations in layer Va (see Marek & Aghajanian, 1999, and references therein). Furthermore, activation of either 5-HT<sub>2A</sub> or  $\alpha_1$ -adrenergic receptors modulates cortical pyramidal cells and interneurons in a parallel fashion (Marek & Aghajanian, 1994; Marek & Aghajanian, 1996b, 1999).

Systemic administration of LSD, mescaline, or other phenethylamine hallucinogens to anesthetized rats decreased spontaneous activity of LC cells but unexpectedly enhanced the activation of LC neurons evoked by sensory stimuli (Aghajanian, 1980; Rasmussen & Aghajanian, 1986; Rasmussen et al., 1986). This effect was not mediated by a direct action of hallucinogens on LC cell bodies because direct microiontophoretic application of the drugs did not have the same effect. Nevertheless, the action did depend on 5-HT<sub>2A</sub> receptor activation because systemic administration of the 5-HT<sub>2A</sub> antagonist ritanserin blocked the effect.

Similarly, systemic but not local administration of DOI suppressed spontaneous LC activity but enhanced responses to somatosensory stimulation, and both effects were blocked by systemic administration of ketanserin (Chiang & Aston-Jones, 1993). DOI-induced suppression of LC firing was blocked by local infusion of GABA antagonists, and the enhanced responses to external stimuli were blocked by an NMDA antagonist. Their results led these investigators to

propose that systemic administration of 5-HT<sub>2</sub> agonists suppressed LC firing indirectly by tonic activation of an inhibitory GABAergic input to the LC. They proposed that the facilitating effect on sensory inputs was mediated through excitatory amino acid receptors in the LC.

In its role as a “novelty detector,” the LC has been viewed as enhancing the signal-to-noise ratio in modulating postsynaptic activity throughout the brain, and the suppression of basal activity concomitantly with enhanced responding to external sensory stimuli would amplify this effect (see Marek & Aghajanian, 1998b, and references therein). Thus, hallucinogens might alter sensory processing in general, in all parts of the brain, but in particular one might speculate that sensory events that may not ordinarily be considered unusual might be perceived as having increased novelty. Indeed, it is a well-known anecdote that under the influence of hallucinogens, very ordinary objects can seem new or novel and can appear fascinating and highly interesting.

Because the LC sends noradrenergic projections to the cortex, where  $\alpha_1$ -adrenergic and 5-HT<sub>2A</sub> receptors have both a similar laminar distribution and similar actions on pyramidal cells, changes in LC firing would also affect pyramidal cell excitability. Although the major site of action of hallucinogens may be 5-HT<sub>2A</sub> receptors localized in PFC areas, it would be very surprising if changes in LC firing patterns induced by hallucinogens also did not modulate the direct effects of 5-HT<sub>2A</sub> agonists on cortical cells.

#### 4.3.4. Functional consequences of serotonin<sub>2A</sub> receptor activation in prefrontal cortex

Identification of the 5-HT<sub>2A</sub> receptor on cortical pyramidal cells as a likely primary target for hallucinogens was an important and exciting finding. What are the functional consequences of receptor activation and what role does this receptor play in the cortex? Several recent studies, including extensive work from George Aghajanian’s laboratory, have provided much insight. The situation has been complicated, however, by the fact that many studies have been carried out in isolated slices of PFC, where hallucinogens lack some of the effects that are seen in the intact animal after systemic administration. For example, the raphe nuclei are the source of 5-HT afferents in the PFC (Moore et al., 1978), yet slice preparations sever this connection. Similarly, slices disconnect the adrenergic input from the LC to the cortex and destroy thalamocortical and corticothalamic circuits. In rat medial PFC (mPFC) slices, direct application of DOI led to a marked increase in extracellular 5-HT, whereas when given systemically DOI led to decreased extracellular 5-HT (Martin-Ruiz et al., 2001). Thus, in vitro slices are useful to assess the direct effects of hallucinogens on cell excitability and cortico-cortico interactions, whereas the conscious intact animal must be employed to provide information about the responses of a functioning thalamo-cortico-pontine network to the actions of these substances.

In early studies of layer II pyramidal cells in piriform cortex, it had been found that activation of 5-HT<sub>2A</sub> receptors

increased spontaneous IPSPs through activation of GABAergic layer III interneurons (Sheldon & Aghajanian, 1990; Gellman & Aghajanian, 1994). This effect was antagonized by low concentrations of the selective 5-HT<sub>2A</sub> receptor antagonist M100907 (Marek & Aghajanian, 1994). These interneurons served as a useful model system because they appear to express no other 5-HT receptor subtypes, whereas PFC pyramidal cells have both 5-HT<sub>1A</sub> and 5-HT<sub>2A</sub> receptors (Araneda & Andrade, 1991). This preparation was subsequently used by Marek and Aghajanian (1996c) to resolve the question of whether hallucinogens were 5-HT<sub>2A</sub> agonists, partial agonists, or antagonists. In that study, both LSD and DOI, at physiologically relevant concentrations, induced concentration-dependent increases in the firing rate of these interneurons. The maximal increases produced by 10 nM LSD and 1  $\mu$ M DOI were about 30% and 50%, respectively. Pretreatment with 1  $\mu$ M DOI did not antagonize the excitatory effect of subsequently applied 5-HT (100  $\mu$ M), and 10 nM LSD pretreatment only reduced the 100  $\mu$ M 5-HT response by about 14%. These data showed that LSD and DOI were potent partial agonists at 5-HT<sub>2A</sub> receptors in piriform cortical interneurons, providing evidence for the hypothesis that hallucinogens were agonists rather than antagonists.

In neocortex, however, focal application of 5-HT to mPFC pyramidal cells leads to two distinct physiological responses (Davies et al., 1987). The first of these was a 5-HT<sub>1A</sub> receptor-mediated hyperpolarization of the cell membrane that appeared to be mediated by an increase in membrane potassium conductance and was blocked by the 5-HT<sub>1A</sub> antagonist BMY 7378 but not by the 5-HT<sub>2A</sub> antagonist ketanserin (Araneda & Andrade, 1991). The 2nd response was composed of at least three components, all of which led to marked enhancement of membrane excitability, and this excitatory response to 5-HT was blocked by the 5-HT<sub>2A</sub> antagonist ketanserin. 5-HT<sub>2A</sub> receptor-mediated depolarization outlasted the 5-HT<sub>1A</sub>-mediated hyperpolarization. The 5-HT-induced depolarization also was rapidly desensitized by high 5-HT concentrations. The hallucinogenic amphetamine DOB mimicked the depolarizing effect of 5-HT but did not cause the initial hyperpolarization observed after 5-HT. The coactivation of both receptor subtypes resulted in a selective enhancement of responsiveness to strong excitatory stimuli with little effect on weaker stimuli. A similar opposing action of 5-HT<sub>1A</sub> and 5-HT<sub>2A</sub> receptors was seen in pyramidal cells of rat cingulate cortex slices, where the depolarizing effect mediated by 5-HT<sub>2A</sub> receptor activation was attributed to a decreased potassium conductance (Tanaka & North, 1993).

In rat PFC neurons, 5-HT induces excitatory postsynaptic potentials (EPSPs), with the most marked effect being an increase in the frequency of spontaneous EPSCs (Aghajanian & Marek, 1997). The effect was concentration dependent with an EC<sub>50</sub> of about 20  $\mu$ M. The 5-HT<sub>2A</sub> antagonist M100907 produced a rightward shift in the dose-response curve and the response was sensitive to Ca<sup>2+</sup> levels and

tetrodotoxin. When 5-HT was administered focally with intracellular recording from the soma of layer V pyramidal cells, “hot spots” were found within apical but not basilar dendritic fields. EPSC responses were most notable when 5-HT was applied near layers IV/Va, with smaller responses obtained from layers I/II. Even at the most sensitive hot spots, however, 5-HT failed to produce steady-state changes in membrane potential. It should be noted that 5-HT rarely induces actual firing of cortical neurons (Aghajanian & Marek, 1997). When a metabotropic glutamate (mGlu) receptor antagonist with presynaptic inhibitory effects was applied concurrently, 5-HT-induced EPSCs were suppressed, suggesting a presynaptic action of 5-HT involving glutamate release and with other data suggesting a release mechanism that was independent of impulse flow.

In a subsequent study, Aghajanian and Marek (1999b) investigated potential mechanisms by which 5-HT could induce glutamate release in the absence of afferent impulse flow. Adding 100  $\mu\text{M}$  5-HT to the medium led to the generation of spontaneous EPSCs in layer V pyramidal mPFC cells. Removal of  $\text{Ca}^{2+}$  from the perfusate blocked the effect, but the  $\text{Ca}^{2+}$  could be replaced by  $\text{Sr}^{2+}$  and spontaneous EPSCs still occurred. The comparable ability of  $\text{Ca}^{2+}$  and  $\text{Sr}^{2+}$  to support the 5-HT-induced late increase in frequency of spontaneous EPSC also pointed to involvement of a presynaptic site of action.

Removing the  $\text{Ca}^{2+}$  from the bath also blocked *electrically evoked* EPSCs in layer V pyramidal cells. When  $\text{Ca}^{2+}$  was replaced with  $\text{Sr}^{2+}$  in these experiments, the evoked EPSCs were blocked, but late “asynchronous” EPSCs still appeared following each stimulus. During washout of the 5-HT from these preparations, late evoked EPSCs also began to appear following some of the stimuli. The authors speculated that initial suppressant effects of 5-HT acting on non-5-HT<sub>2A</sub> (5-HT<sub>1A</sub>?) receptors may initially mask the longer-acting depolarizing effects mediated by 5-HT<sub>2A</sub> receptors. This asynchronous or late effect was characterized by the presence of small EPSCs that can persist for ~500–1000 ms following evoked synchronous EPSC but with a slightly longer latency (~50 ms) than the immediate electrically evoked synchronous EPSCs. Local application of both the hallucinogenic phenethylamine DOI (Aghajanian & Marek, 1999b) and LSD promoted this late component of electrically evoked EPSPs (Aghajanian & Marek, 1998, 1999a).

Thus, hallucinogens increase both spontaneous and electrically evoked responses in cortical neurons. The effect on spontaneous EPSCs is relatively small, whereas the increase in both early (Aghajanian & Marek, 1997) and late (or asynchronous; Aghajanian & Marek, 1999a, 1999b; Marek et al., 2000) components of electrically evoked EPSCs is more robust. Although evidence is discussed Section 4.3.4.1 regarding whether the spontaneous EPSCs may result from a presynaptic release of glutamate from thalamocortical terminals, the vast majority of fibers activated by electrical stimulation are of cortico-cortico origin (G. Aghajanian,

personal communication). Thus, the most prominent electrophysiological action of hallucinogens appears to be observed in effects on cortico-cortico interactions.

**4.3.4.1. Effects on cortical glutamate.** An overarching theme that has emerged in about the past five years is that hallucinogens enhance glutamatergic transmission in the cortex. Significant controversy still centers, however, on the details of the mechanism whereby hallucinogens increase cortical glutamate following activation of 5-HT<sub>2A</sub> receptors. An anatomical basis for this effect is seen in the fact that the heaviest density of mGlu2/3 receptor binding in the mPFC is found in layers I and Va, with a laminar distribution similar to 5-HT<sub>2A</sub> receptors (Marek et al., 2000).

Electrophysiological data first suggested that 5-HT<sub>2A</sub> receptors amplify glutamate-induced EPSPs from apical dendrites of pyramidal cells by increasing a persistent sodium channel (Marek & Aghajanian, 1996a). These effects appear to be mediated by release of glutamate, induced by the stimulation of presynaptic 5-HT<sub>2A</sub> heteroreceptors, and the subsequent activation of  $\alpha$ -amino-3-hydroxy-5-methylisoxazole-4-propionate (AMPA) receptors (Aghajanian & Marek, 1997, 1999b, 1999c; Marek et al., 2000). Selective group II mGlu agonists blocked DOI-induced glutamate release in the PFC, presumably by a presynaptic agonist action (Marek et al., 2000), and also reversed the behavioral deficits produced by DOI (Gewirtz & Marek, 2000). Presynaptic 5-HT<sub>2A</sub> heteroreceptor facilitation of glutamate release has also been proposed as a mechanism in dorsolateral septal nucleus, where 5-HT similarly enhanced EPSPs and EPSCs when inhibitory GABA receptors were blocked (Hasuo et al., 2002).

Recently, Marek et al. (2001) found that lesions of the medial thalamus in rats led to a significant decrease in the frequency of 5-HT-induced EPSCs recorded from layer V pyramidal cells. Autoradiographic experiments showed that medial thalamic lesions also led to a significant decrease in the density of group II mGlu2/3 receptors in the mPFC, consistent with the loss of presynaptic glutamate terminals. Unexpectedly, however, these lesions led to *increased* density of cortical 5-HT<sub>2A</sub> receptors, a finding that would not be entirely consistent with presynaptic 5-HT<sub>2A</sub> receptor localization. Large bilateral lesions of the amygdala, the other source of glutamate afferents to the prelimbic region of the cortex, had no effect on 5-HT-induced EPSCs in layer V pyramidal cells.

The somatosensory cortex (SSC) displays a strong response of the immediate-early gene product *c-fos* to acute DOI challenge (Moorman & Leslie, 1996) and also receives glutamatergic projections from the ventrobasal thalamus. DOI induces *c-fos* expression in a band of neurons spanning superficial layer V to deep layer III, an area in register with the apical dendritic fields of cortical pyramidal cells (Moorman & Leslie, 1996; Mackowiak et al., 1999; Scruggs et al., 2000). Interestingly, *c-fos*-expressing neurons were more



concentrated in septa than in barrels, suggesting that DOI activated intercortical projections. The enhanced *c-fos* expression was blocked by the 5-HT<sub>2A</sub> antagonist M100907 but not by the 5-HT<sub>2C</sub> antagonist SB 206553 (Scruggs et al., 2000). The vast majority of *c-fos*-positive cells in the SSC, however, do not express 5-HT<sub>2A</sub>-like immunoreactivity (Mackowiak et al., 1999; Scruggs et al., 2000), suggesting that the increase in DOI-induced *fos* expression is indirectly mediated.

Similar results were obtained with LSD by Gresch et al. (2002). Administration of LSD (0.5 mg/kg i.p.) led to a significant increase in *fos*-like immunoreactivity in the rat PFC and anterior cingulate that was completely blocked by pretreatment with the specific 5-HT<sub>2A</sub> antagonist M100907. Double staining for both *fos* immunoreactivity and 5-HT<sub>2A</sub> receptor revealed that LSD did not induce *fos* in pyramidal cells expressing 5-HT<sub>2A</sub> receptors in either parietal cortex or PFC. Increased *fos* expression was induced in cells in cortical layers III and IV, with only rare occurrence of a doubly labeled pyramidal cell, again suggesting *fos* induction by an indirect mechanism.

Suggestions that the *c-fos* response may be indirectly mediated are consistent with other studies providing evidence that the effect of DOI on *c-fos* expression is mediated through alterations in glutamate release from thalamocortical afferents. Marek and Gewirtz (1999) had previously reported that DOI-induced EPSCs in layer V pyramidal cells were blocked by medial thalamic lesions. Thus, Scruggs et al. (2000) hypothesized that DOI acts on 5-HT<sub>2A</sub> receptors located on thalamocortical afferents to increase glutamate release onto nonpyramidal glutamatergic cells, leading to an increase in *c-fos* expression within these target neurons. This hypothesis was consistent with their finding that lesions to the ventrobasal thalamus that ablated thalamocortical glutamatergic projections to cortex attenuated the ability of DOI to induce *c-fos* expression and also significantly decreased the number of *c-fos*-immunoreactive terminals in the SSC (Scruggs et al., 2000). Further, pretreatment with an AMPA antagonist completely blocked DOI-elicited *c-fos* expression. These workers interpreted their data to mean that DOI induced *c-fos* expression in cortical neurons by acting on 5-HT<sub>2A</sub> receptors located on glutamatergic thalamic afferents to the SSC, a conclusion in agreement with that of others (Aghajanian & Marek, 1999b; Marek & Gewirtz, 1999, 2000). Their data also suggested that DOI activated intercortical projections because *fos* was primarily increased in the projection (septa) neurons of the SSC.

In similar studies, the potent and selective mGlu2/3 agonist LY379268 attenuated the DOI-induced increase in *c-fos* mRNA levels in rat mPFC slices (Zhai et al., 2003). DOI enhanced the amplitude of the complex EPSP evoked in pyramidal neurons by 30%, an effect that was blocked by LY379268, demonstrating that excitatory glutamatergic responses of PFC pyramidal neurons are positively and negatively modulated by 5-HT<sub>2A</sub> and mGlu2/3 receptors, respectively. LY379268 also suppressed an increase in the

frequency of spontaneous EPSPs induced by bath-applied DOI in layer V pyramidal cells recorded in the mouse medial frontal cortex (Klodzinska et al., 2002).

Scruggs et al. (2003) recently reported studies using *in vivo* microdialysis to measure extracellular glutamate levels in the rat SSC. Systemic administration of DOI led to a slow but sustained increase in extracellular glutamate. Intracortical delivery of DOI by reverse dialysis also significantly increased extracellular glutamate and this effect was blocked by concomitant intracortical dialysis of the selective 5-HT<sub>2A</sub> antagonist M100907.

In spite of accumulating evidence that hallucinogens induce glutamate release *in vivo*, Arvanov et al. (1999a, 1999b) have challenged the hypothesis that release of glutamate from presynaptic terminals is the mechanism of action for hallucinogens (Aghajanian & Marek, 1997; Marek & Aghajanian, 1998b). Rather, they reported a gradually emerging, 5-HT<sub>2A</sub>-mediated *inhibitory* effect of LSD and DOB on NMDA-induced inward current and NMDA receptor-mediated neurotransmission in pyramidal cells. They did observe a facilitating action of DOB on a NMDA-induced inward current that was blocked by both the selective 5-HT<sub>2A</sub> antagonist M100907 and the non-NMDA receptor antagonist CNQX, consistent with the hypothesis of a 5-HT<sub>2A</sub>-mediated presynaptic release of glutamate. Most importantly, however, the concentration of LSD required to produce a facilitatory effect on the NMDA current was 8-fold higher and *nonphysiological* (500–2000 nM). Conversely, the IC<sub>50</sub> values for LSD and DOB to *inhibit* this NMDA response were 9 and 130 nM, respectively, and within a physiologically relevant range. The inhibitory effects of both LSD and DOB were also blocked by the 5-HT<sub>2A</sub> antagonist M100907 but not by a selective 5-HT<sub>1A</sub> receptor antagonist. Furthermore, the non-hallucinogenic ergoline lisuride and the DOM analogue BL3912A were *inactive* in this response. Further mechanistic studies with several inhibitors indicated that the inhibitory effect was mediated through a Ca<sup>2+</sup>/calmodulin kinase II-dependent signal transduction pathway.

Other problems with the presynaptic glutamate release hypothesis include the fact that immunocytochemistry studies have found that the majority (73%) of 5-HT<sub>2A</sub>-immunopositive profiles were postsynaptic processes, with only 24% of identifiable immunoreactive profiles on presynaptic structures (Miner et al., 2003). In the latter study, these structures rarely formed synaptic contacts in single sections. Furthermore, mediodorsal thalamic cell bodies have little or no mRNA for the 5-HT<sub>2A</sub> receptor (Pompeiano et al., 1994; Cyr et al., 2000). Nevertheless, Jakab and Goldman-Rakic (1998) did detect 5-HT<sub>2A</sub> receptor in a minor group of asymmetric synapse-forming cortical axons so it is still possible that this receptor, even if located on only a small percentage of presynaptic terminals, may modulate significant glutamate transmission.

An alternative mechanism for glutamate release has been suggested that involves the release of a retrograde transmit-



ter following activation of postsynaptic 5-HT<sub>2A</sub> receptors. For example, certain voltage-gated potassium (Kv) currents are critically involved in regulating glutamate terminal excitation. Lambe and Aghajanian (2001) found that  $\alpha$ -dendrotoxin (DTX), a well-characterized blocker of certain Kv1 members, mimicked the effect of 5-HT by inducing EPSCs preferentially in layer V pyramidal neurons. DTX significantly occluded EPSCs induced by 5-HT, suggesting a common mechanism of action. Following studies with a series of specific potassium channel blockers, these workers concluded that Kv1.2-containing potassium channels were likely essential for the observed DTX-induced EPSCs. Furthermore, lesions in the anterior thalamus led to a dramatic attenuation of EPSCs in response to DTX (only 1 of 9 animals showed the normal response to DTX). Therefore, these investigators hypothesized that blockade of Kv1.2-containing potassium channels was part of the mechanism underlying 5-HT-induced glutamate release from thalamocortical terminals that led to spontaneous EPSCs.

As one possible mechanism for this action that would not depend on direct activation of 5-HT<sub>2A</sub> receptors on presynaptic terminals, Lambe and Aghajanian (2001) have suggested that 5-HT<sub>2A</sub> receptor activation on postsynaptic cells may lead to release of a retrograde messenger. This substance would then diffuse out from the postsynaptic membrane and block K<sup>+</sup> channels on presynaptic terminals. As discussed earlier in this review and noted by these investigators, one of the two known major signaling events following 5-HT<sub>2A</sub> receptor activation is stimulation of PLA<sub>2</sub>, leading to release of AA into the medium. Because behavioral effects of hallucinogens in rodents do not correlate with the ability of 5-HT<sub>2A</sub> receptor agonists to activate PLC signaling, it has been suggested that the generation of AA may be the more relevant second messenger for the actions of hallucinogens (Kurrasch-Orbaugh et al., 2003b). As noted earlier in this review, Qu et al. (2003) also showed that administration of DOI to rats led to significantly increased incorporation of [<sup>3</sup>H]AA in brain. It is very interesting, therefore, that AA is an extracellular blocker both of Kv1.2 homomers in expression systems and at least one member of the high-voltage-activated Kv3 family (Poling et al., 1995, 1996). It would be a very interesting experiment to determine whether PLA<sub>2</sub> inhibitors could block the spontaneous EPSCs induced in pyramidal neurons by application of a 5-HT<sub>2A</sub> agonist.

The findings by Arvanov et al. (1999a, 1999b) that the mechanism of action for hallucinogens may involve an effect on NMDA receptors, discussed earlier, are also intriguing because of the recent report by Xia et al. (2003) that the 5-HT<sub>2A</sub> receptor directly associates with the prominent PSD-95 protein (Cho et al., 1992; Kistner et al., 1993). Both PSD-95 and the 5-HT<sub>2A</sub> receptor are enriched in asymmetric synapses and dendritic spines of cortical pyramidal neurons (Aoki et al., 2001; Prange & Murphy, 2001).

An association between PSD-95 and the 5-HT<sub>2A</sub> receptor is potentially very important because PSD-95 is preferentially targeted to dendritic spines where it is thought to

interact directly with NMDA- and AMPA-type glutamate receptors (Kornau et al., 1995, 1997; Sheng, 2001; Tomita et al., 2001). NMDA receptors are clustered at synaptic sites through interactions with PDZ domain-containing scaffolding proteins (Kornau et al., 1995; Kim et al., 1996; Muller et al., 1996; Niethammer et al., 1996). PSD-95 colocalizes with the NR2B subunit of the NMDA receptor in cultured hippocampal neurons and in situ hybridization studies have shown that PSD-95 is expressed in most rat brain neuronal populations (Kornau et al., 1995). Further, these latter workers found that both proteins were concentrated along dendrites at putative synaptic sites in dense clusters. Overexpression of PSD-95 in rat PFC neurons resulted in preferential targeting to dendritic spines (Beique & Andrade, 2003). In these latter studies, however, the major effect was on AMPA receptor expression at synapses rather than on NMDA receptors.

Although Xia et al. (2003) did not examine the possibility that the 5-HT<sub>2A</sub> receptor was associated with ionotropic glutamate receptors through the intermediacy of PSD-95, it does seem likely that such a complex might form and that agonist effects at the 5-HT<sub>2A</sub> receptor might thus modulate AMPA and/or NMDA receptor function. It might be noted that in rat mPFC slices the NMDA receptor antagonist AP5 completely blocked the late component of the evoked EPSC seen in the presence of DOI but had little effect on the early evoked component (Stutzmann et al., 2001).

Thus, the results of Arvanov et al. (1999a, 1999b), discussed above, may reflect a direct modulatory interaction of 5-HT<sub>2A</sub> receptors on NMDA receptors. Further electrophysiological studies will be required to examine this possibility.

These somewhat divergent but very interesting findings raise another interesting issue. Because DOI is not a controlled substance and is readily available from commercial sources, it is typically the drug of choice for studies of hallucinogens. Furthermore, it is chemically stable, whereas LSD solutions are best made fresh and must be kept in darkness to avoid chemical decomposition. Thus, virtually all of the recent studies on the mechanism of action of hallucinogens in rodents have employed only DOI. Because LSD has in vivo potency that far exceeds what would be expected by its affinity/intrinsic activity at 5-HT<sub>2A</sub> receptors, any comprehensive explanation for the actions of hallucinogens must include studies of LSD and explain why it has uniquely high potency. Thus, the reports by Arvanov et al. (1999a, 1999b) provide provoking and challenging data that should give impetus to more detailed electrophysiological studies using LSD, and perhaps other tryptamine hallucinogens such as psilocin, and not use only DOI or another phenethylamine. Mechanistic hypotheses with the greatest explanatory power will derive from studies that employ several different chemical types of hallucinogens as well as inactive congeners.

There is one other important consideration to keep in mind with respect to all of the electrophysiology studies of

cortical cells discussed above. The neocortex is constantly active *in vivo*, as cortical and subcortical networks generate rhythmic patterns of activity at a variety of frequencies, including a “slow rhythm” characterized by the recurrence of tonic activity in cortical neurons approximately once every 3–5 sec (Steriade et al., 1993). The propagation and synchronization of this slow oscillation depends at least in part on cortico-cortical connections and is proposed to be generated by recurrent excitation among large networks of cortical neurons.

All of the *in vitro* electrophysiological studies of cortical slices discussed in this review appear to have employed a “traditional” and almost identical slice bath composition. As noted by Sanchez-Vives and McCormick (2000), when ferret PFC slices are maintained *in vitro* in the traditional bathing medium, *no* spontaneous rhythmic activity is observed. When, however, these workers used a bath solution with an ionic composition that closely mimicked that of brain interstitial fluid, spontaneous rhythmic oscillations appeared and could be continuously maintained that were nearly identical to those occurring *in vivo*. The slow oscillation was most robust and occurred first in or near layer V following a short delay by activity in deeper layers. The activity maximum in layer V was always larger and persisted longer than in any other layers and seemed to be initiated in layer V as an excitatory interaction between pyramidal neurons that propagated through the neocortex. These workers suggest that the basic operation of cortical networks is the generation of self-maintained depolarized states that are tightly regulated through interaction with local GABAergic neurons and intrinsic membrane conductances. They suggest that the ability of cortical networks to generate persistent and recurring activities even in the absence of ongoing subcortical inputs may be a process that underlies perceptual influences on sensory information processing. Unfortunately, no one has yet examined the effect of hallucinogens on spontaneous rhythmic activity in cortical circuits, experiments that would likely provide important new data.

There is already fairly extensive evidence for the interaction of glutamate systems in 5-HT-mediated behaviors. For example, DOI-induced head twitches in mice are mediated by 5-HT<sub>2A</sub> receptor activation but were inhibited in a dose-dependent manner by the selective mGlu2/3 agonists LY354740 and LY379268 (Klodzinska et al., 2002). DOI-induced head shakes in rats are also mediated by activation of 5-HT<sub>2A</sub> receptors. Administration of the mGlu2/3 receptor agonist LY354740 attenuated the frequency of DOI-induced head shakes in rats, whereas administration of the selective mGlu2/3 antagonist LY341495 potentiated DOI-induced head shakes in rats (Gewirtz & Marek, 2000). As noted earlier, this effect is presumably due to a presynaptic effect on glutamate neurons, where mGlu2/3 agonists suppress glutamate release, and antagonists block the presynaptic autoreceptor agonist effect of endogenously released glutamate. All of these data indicate that group II

mGlu receptor agonists counteract the effects of hallucinogenic drugs.

Both competitive and noncompetitive NMDA receptor antagonists markedly enhanced the 5-HT-mediated (*i.c.v.*) head-twitch response (HTR) in mice (Kim et al., 1998). In contrast, NMDA itself inhibited 5-HT-induced HTR in mice. Both competitive and noncompetitive NMDA receptor antagonists also markedly enhanced 5-HT-induced HTR in mice that had been treated with *p*-chlorophenylalanine (PCPA) to deplete endogenous 5-HT (Kim et al., 1999). The enhancement of 5-HT-induced HTR was also inhibited by the DA agonist apomorphine and the 5-HT<sub>2</sub> receptor antagonist cyproheptadine. The authors concluded that NMDA receptors play an important role in the glutamatergic modulation of the head-twitch serotonergic function mediated through postsynaptic 5-HT<sub>2</sub> receptors (Kim et al., 1999). In a similar study, head shakes in rats induced by DOI were enhanced by the NMDA antagonist dizocilpine (Dall’Olio et al., 1999).

Although the focus of most research on amino acid neurotransmitters in frontal cortex has been on glutamate, GABA interneurons may also play an important role. Using *in vivo* microdialysis in rat mPFC, administration of DOI through the perfusion probe led to a significant dose-dependent increase in extracellular GABA (Abi-Saab et al., 1999). Double-labeling immunohistochemical examination of cortical cells following systemic administration of DOI showed a significant increase in the number of interneurons expressing both glutamic acid decarboxylase (GAD) and *fos*-like immunoreactivity. These workers concluded that 5-HT regulates cortical GABA interneurons, an effect similar to that seen in piriform cortex interneurons (Marek & Aghajanian, 1994). In rat frontal cortex, 5-HT-enhanced spontaneous IPSPs in pyramidal cells can be produced through activation of 5-HT<sub>2A</sub> receptors located on GABAergic interneurons (Zhou & Hablitz, 1999). Thus, activation of 5-HT<sub>2A</sub> receptors in cortex can produce both excitation and a feed-forward inhibition of cortical pyramidal cells.

Although the situation is undoubtedly much more complex, one can envision plausible mechanisms of action for hallucinogens. The studies by Araneda and Andrade (1991) have shown that 5-HT hyperpolarizes and depolarizes layer V pyramidal neurons by activation of 5-HT<sub>1A</sub> and 5-HT<sub>2A</sub> receptors, respectively. Normal firing of raphe cells in an awake animal provides tonic 5-HT release into cortical areas, where extracellular 5-HT levels are about five times higher during waking than during slow-wave sleep (de Saint et al., 2000). Depending probably on axonal localization, types of synaptic interactions, volume transmission effects, and rate of raphe cell firing, either or both 5-HT<sub>1A</sub> and 5-HT<sub>2A</sub> receptors would be activated.

In the intact animal, systemic administration of a hallucinogen suppresses raphe cell firing either directly through activation of 5-HT<sub>1A</sub> receptors (tryptamines) or indirectly by stimulation of inhibitory GABA neurons (Liu et al., 2000),

and there would be little or no tonic activation of either cortical 5-HT<sub>1A</sub> or 5-HT<sub>2A</sub> receptors. Local concentrations of a 5-HT<sub>2A</sub> agonist in the cortex following systemic administration would thus stimulate 5-HT<sub>2A</sub> receptors localized on pyramidal cells, unopposed by inhibitory 5-HT<sub>1A</sub> receptor activation.

The hallucinogen would also stimulate putative excitatory 5-HT<sub>2A</sub> receptors on glutamate axon projections from the thalamus, although as discussed above, this might be through some as yet undefined indirect mechanism. The overall effect would be to increase excitability of cortical pyramidal cells while at the same time providing release of glutamate into cortical neuronal fields. This explanation is consistent with the conclusions of [Martin-Ruiz et al. \(2001\)](#). Although mediodorsal thalamic projections would normally fire in response to sensory information processed by the thalamus, the actions of hallucinogens directly on these terminals would evoke glutamate release in the absence of appropriate sensory input. Further, because pyramidal cells would now be hyperexcitable, the effects of extracellular glutamate would be potentiated. One could envision, therefore, that hallucinogens greatly enhance sensitivity/excitability of cortical processing while at the same time inducing glutamate release from thalamic afferents that normally signal incoming sensory information to be processed. That is, the signal-to-noise ratio in the cortex for incoming sensory inputs from the thalamus would be very low. Such reasoning is generally consistent with empirical observations that the effects of hallucinogens include greatly amplified or distorted incoming sensory stimuli and that sensory gating or filtering mechanisms are impaired.

[Vollenweider and Geyer \(2001\)](#) propose that hallucinogens disrupt information processing in cortico-striato-thalamo-cortical (CSTC) feedback loops, leading to an inability to screen out or “gate” extraneous stimuli and to attend selectively to salient features of the environment, features that to some extent may parallel those seen in the very early stages of schizophrenia. They propose that nonphysiological disruptions of thalamic gating of sensory and cognitive information lead to an “overload” of the processing capacity of the cortex and that hallucinogens may alter thalamo-cortical transmission by stimulation of 5-HT<sub>2A</sub> receptors in several components of the CSTC, including the PFC, striatum, nucleus accumbens, and thalamus. This overall view may be modified slightly by considering that hallucinogens appear directly to induce presynaptic release of excess glutamate from thalamic afferents, thus producing the equivalent of “sensory overload” in the cortex that is independent of actual sensory input to the thalamus.

The effect of hallucinogens on thalamic function, and particularly the reticular nucleus of the thalamus, is a subject that so far has been almost completely neglected but which seems of potentially great importance. Activation of 5-HT<sub>2A</sub> receptors in thalamic nuclei has the potential to produce marked alterations or disruptions in sensory processing. In particular, the thalamic reticular nucleus can direct “atten-

tion” through its inhibitory GABAergic input to all other thalamic nuclei and assists in organizing activity in specific thalamic nuclei according to characteristics of sensory input and attentional demands ([Smythies, 1997](#); [Behrendt, 2003](#)). In tonic mode, the firing of thalamic relay cells is related to afferent sensory input, whereas in burst-firing mode, sensory information is not effectively transmitted ([McCormick & Feuser, 1990](#)). Inhibitory input from the reticular thalamic nucleus hyperpolarizes thalamic relay cells and can switch their response mode to burst firing and prevent them from reaching the firing threshold in response to accumulating sensory inputs. Several studies discussed in this review have shown that 5-HT<sub>2A</sub> receptors often activate inhibitory GABA interneurons, leading to speculation that 5-HT<sub>2A</sub> receptor activation in the reticular thalamic nucleus might indeed increase the level of inhibitory input to relay cells. Dysfunction of the reticular nucleus would lead to loss of sensory-specific inhibition of specific thalamic nuclei and further impairment of the signal-to-noise ratio. “Noise” could then predominate over stimulus-specific activity, with relay cells being recruited into thalamocortical circuits without receiving adequate sensory input. The combination of increased thalamic relay cell excitability and reticular thalamic nucleus dysfunction could lead to activation of thalamocortical circuits and the formation of coherent assemblies of thalamocortical oscillations that would be independent of afferent sensory inputs, potentially giving rise to underconstrained perception, such as hallucinations or dream imagery ([Behrendt, 2003](#)).

[Fig. 1](#) illustrates in a very simplistic way the interconnections between some of the structures known to express 5-HT<sub>2A</sub> receptors. In the context of this model, one should thus consider that hallucinogens may produce marked alterations in ascending brainstem activating systems, disturbance in thalamic function, both in gating sensory input and in afferent firing in cortical terminal fields, and changes both in cortical cell excitability and in cortico-cortico interactions.

Although it will require a great deal more research to elucidate fully such a scheme, it is apparent that hallucinogenic 5-HT<sub>2A</sub> agonists can be very useful molecular tools for such studies. A major focus of future research should be to carry out studies to show whether 5-HT<sub>2A</sub> receptors are localized on glutamate terminals. Furthermore, additional electrophysiological studies of cortical pyramidal cells using LSD and hallucinogens other than DOI should be carried out to resolve the issues raised by the [Arvanov et al. \(1999a, 1999b\)](#) studies. Although the complete circuitry may remain elusive, it seems likely that more definitive explanations can be offered following a focus on these two key points. Future studies with brain slices should also employ a bathing medium with an ionic composition that more nearly reflects the interstitial fluid in the brain to discern the effect of hallucinogens on persistent and recurring activity in cortical networks. Finally, there is a need to examine in detail the effects of hallucinogens on thalamic function.

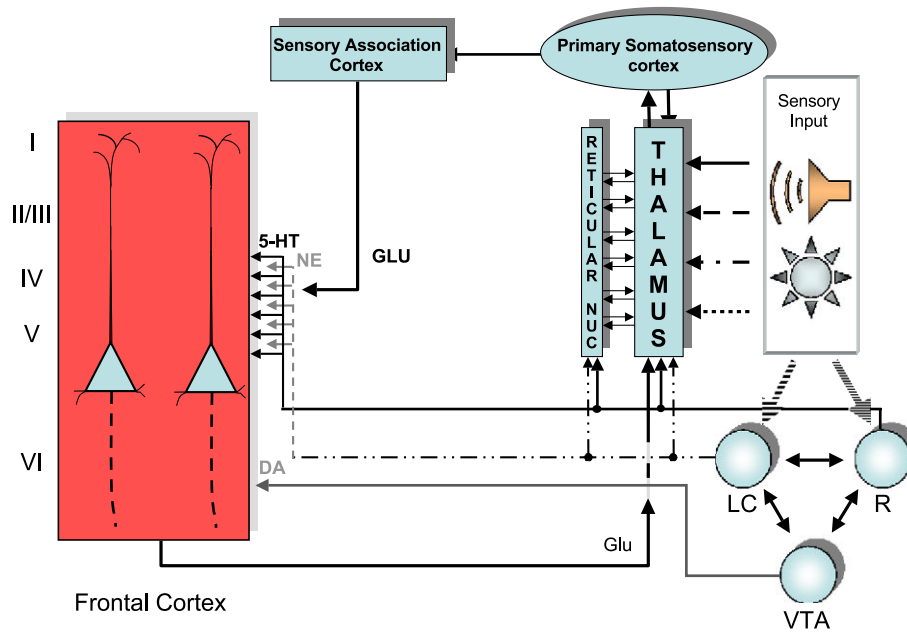

Fig. 1. A simple diagram of possible interactions between brain areas that are affected by 5-HT<sub>2A</sub> agonist actions of hallucinogens. In PFC, 5-HT<sub>2A</sub> receptors are localized on the proximal portion (deep layer IV/superficial layer V) of apical dendrites and dendritic spines on pyramidal cells. R (raphe nucleus) sends serotonin projections to all forebrain structures, including the frontal cortex. Hallucinogens reduce firing of raphe cells either directly by stimulation of 5-HT<sub>1A</sub> receptors or indirectly by 5-HT<sub>2A</sub> receptor activation of inhibitory GABA interneurons. Cessation or reduction of raphe cell firing would lead to a disruption of normal serotonergic tone, which would include reduced activation of inhibitory 5-HT<sub>1A</sub> receptors on cortical pyramidal axons. Essentially all incoming sensory information is processed through the thalamus, with modulation by the reticular nucleus of the thalamus, which has afferents from specific thalamic nuclei and associated cortical areas. Many thalamic nuclei as well as the reticular nucleus express 5-HT<sub>2A</sub> receptors. Alterations in the firing mode of thalamic neurons are associated with dramatic changes in the neuron's responsiveness to peripheral stimuli (McCormick & Bal, 1997). Both LC and VTA express 5-HT<sub>2A</sub> receptors and receive input from the raphe. The LC sends noradrenergic projections to both thalamus and cortex. Hallucinogens potentiate burst firing in LC neurons in response to novel stimuli. Stimulation of  $\alpha_1$ -adrenergic receptors in cortex depolarizes pyramidal cells and appears to share a common G<sub>q</sub>-coupled PLC pathway with 5-HT<sub>2A</sub> receptors. VTA cells are depolarized by activation of 5-HT<sub>2A</sub> receptors, which would potentially lead to enhanced release of DA in cortex. There is extensive evidence that a significant portion of 5-HT, NE, and DA release in the cortex may have effects on cortical neurons through volume transmission rather than direct synaptic connections.

**4.3.4.2. Hallucinogens increase cortical metabolism.** Increased release of glutamate in response to hallucinogen administration would be expected to enhance cortical metabolic activity. The most extensive human work in this area has been reported by Franz Vollenweider and his colleagues at the Psychiatric University Hospital of Zurich. Coupling studies using the PET ligand [<sup>18</sup>F]FDG, with Dittrich's APZ questionnaire (Dittrich, 1998), a rating scale for ASC, various changes in mood and perception have been correlated with changes in cerebral metabolic rate of glucose (CMRglu; Vollenweider, 2001). Dittrich's instrument reliably measures shifts in mood, thought disorder, and changes in the experience of the self/ego and of the environment in both drug-induced and non-drug-induced ASC. Administration of an effective dose of psilocybin produced a global increase in CMRglu bilaterally in the frontomedial and frontolateral cortices, including the anterior cingulate, areas with a high density of 5-HT<sub>2A</sub> receptors. The most marked increases (24–25%) were observed in the frontomedial and frontolateral cortices, anterior cingulate, and temporomedial cortex. A slightly smaller CMRglu increase was seen in the basal ganglia, with the smallest increases found in the sensorimotor (14.7%) and occipital (14.4%) cortices. The

increases of CMRglu in the PFC, anterior cingulate, temporomedial cortex, and putamen were positively correlated with psychopharmacological effects assessed with Dittrich's APZ. Correlational analysis revealed that metabolic hyperfrontality was associated with a depersonalization/derealization syndrome, thought disturbances, and mania-like symptoms (Vollenweider et al., 1997b). Their data indicate that 5-HT<sub>2A</sub> receptor activation leads to a hyperfrontal metabolic pattern (Vollenweider et al., 1997b). Although metabolic hypofrontality is observed in chronic schizophrenia, hyperfrontality is a characteristic of acute schizophrenia. Thus, the effect of hallucinogens has been used, particularly in Europe, as a model of acute psychosis and schizophrenia.

In another double-blind, placebo-controlled human PET study using psilocybin and [<sup>18</sup>F]FDG, Gouzoulis-Mayfrank et al. (1999) also measured metabolic rate of glucose (MRGlu) in several brain regions of interest when subjects performed an activation task that consisted of associating one word to a stimulus word, with the control task being simply repetition of the stimulus word. The metabolic pattern observed was characterized by relative hypermetabolism in the prefrontal and inferior temporal regions and



relative hypometabolism in subcortical regions. The most striking finding was a metabolic increase of nearly 10% in the right anterior cingulate. This activity correlated positively with stereotyped thoughts and negatively with anxiety. Decreased metabolism in the left thalamus was linked to general psychopathology, tension, anxiety, and depressed feelings.

Similarly, in a study by Hermle et al. (1998), male subjects were given 500 mg of mescaline sulfate (p.o.) and significant psychological effects were again measured using Dittrich's APZ questionnaire (Dittrich, 1998). Using single-photon emission computed tomography (SPECT) to measure regional blood flow, mescaline produced a pronounced increase in the right anterior cortical regions; a "hyperfrontal" pattern with some emphasis on the right hemisphere, which was correlated with mescaline-induced psychotic psychopathology as measured with the APZ (Oepen et al., 1989; Hermle et al., 1992, 1998).

In a rat study, injection of DOI (2 mg/kg i.p.) or mescaline (10 mg/kg i.p.) at an ambient temperature of 29°C produced a 35–45% decrease in brain glycogen that persisted for at least 2 hr (Darvesh & Gudelsky, 2003). DOI also increased the extracellular striatal glucose concentration by 60%. When the experiment was carried out at 22°C, the DOI-induced glycogenolysis and hyperthermia were significantly attenuated as was the increase in the extracellular concentration of glucose in the striatum. The DOI-induced hyperthermia, glycogenolysis, and increase in the extracellular glucose concentration were attenuated when the rats were treated with the 5-HT<sub>2A/2C</sub> receptor antagonist LY53857. These results support the conclusion that 5-HT<sub>2A/2C</sub> receptor activation promotes glycogenolysis and that hyperthermia exerts a prominent role in this process.

By contrast, Freo et al. (1991) have reported that administration of DOI to male Fisher 344 rats led to decreased regional cerebral metabolic rates using quantitative autoradiography of [<sup>14</sup>C]-2-deoxyglucose in 75 different brain regions. Higher doses produced even larger decrements in metabolic rates. It is difficult to reconcile this result with human studies, where glutamate release would be expected to increase cortical metabolic activity, and with the study by Darvesh and Gudelsky (2003), where DOI increased cortical glucose concentrations.

**4.3.4.3. Dopaminergic effects of hallucinogens.** Although there is substantial evidence for the importance of glutamate systems in the actions of hallucinogens, it appears likely that at least some hallucinogens may also activate DA pathways, either directly as with LSD or indirectly by compounds that lack significant DA receptor affinity. Based on the psychopharmacology of DA compounds, which typically possess CNS stimulant effects, this action could be relevant. Although studies of the DA effects of hallucinogens are sparse, this area appears promising for further study. It is intriguing to consider the possibility that hallucinogens may activate brain DA systems but that, in contrast to virtually all other

drugs that increase DA transmission, they fail to produce dependence, as discussed in Section 1.2. It certainly seems possible that in response to hallucinogen administration, cortical areas might receive increased DA activation, whereas areas such as the nucleus accumbens that are thought to be involved in reward mechanisms might not be activated. In studies of *fos* induction by LSD, Erdtmann-Vourliotis et al. (1999) and Gresch et al. (2002) have reported that LSD did not induce *fos* in the rat nucleus accumbens following LSD administration. The latter workers note that this finding is consistent with the reports that LSD is not reinforcing in animal models of drug dependence.

It is known that the VTA receives serotonergic afferents from the raphe nuclei, where they form synapses with DA dendrites (see Doherty & Pickel, 2000, and references therein), that Cornea-Hebert et al. (1999) identified somatodendritic localization of 5-HT<sub>2A</sub> receptors in the VTA, and that depolarization of DA cells in VTA slice preparations can be blocked by the 5-HT<sub>2A</sub> antagonist ketanserin (Pessia et al., 1994).

A recent electron microscopic immunocytochemical study showed localization of 5-HT<sub>2A</sub> receptors in both parabrachial (PB) and paranigral (PN) regions of the VTA, with labeled profiles identified primarily as dendrites and unmyelinated axons (Doherty & Pickel, 2000). Dendrites commonly showed 5-HT<sub>2A</sub> receptor immunoreactivity and tyrosine hydroxylase (TH) colocalization. Thus, 5-HT<sub>2A</sub> receptor activation may directly affect local dendritic release of DA as well as release of DA in mesocortical and mesolimbic terminal fields. A substantial number of 5-HT<sub>2A</sub>-labeled dendrites were also detected that did not contain TH immunoreactivity, suggesting 5-HT<sub>2A</sub> receptor modulation of other non-DA, perhaps GABAergic, interneurons in the VTA.

In a recent study using fluorescence immunohistochemistry with confocal microscopy, Nocjar et al. (2002) found that 5-HT<sub>2A</sub> receptors were colocalized, in part, to TH-containing cells throughout all subnuclei of the VTA, most prominently in the anterior region and principally within the rostral and mid-PN, PB, and intrafascicular nuclei (IF). Thus, activation of 5-HT<sub>2A</sub> receptors by hallucinogens would be expected to modulate DA activity of VTA cells directly or indirectly through non-DA neurons and affect DA release from projections in cortical and limbic structures.

Using *in vivo* microdialysis in the rat mPFC, Pehek et al. (2001) found that direct infusion of the selective 5-HT<sub>2A</sub> antagonist M100907 through the dialysis probe produced a concentration-dependent block of K<sup>+</sup>-stimulated DA release. Direct infusion of M100907 into the mPFC also blocked increased extracellular DA produced by systemically administered DOI. These workers concluded that activation of cortical 5-HT<sub>2A</sub> receptors potentiated the phasic release of mesocortical DA.

Similarly, using microdialysis in the rat nucleus accumbens, local infusion of DOI gave a dose-dependent increase in extracellular DA (Yan, 2000). Perfusion of a 5-HT<sub>2A</sub>

antagonist alone had no effect on basal DA levels. The increased DA induced by perfusion with 100  $\mu$ M DOI was sensitive to tetrodotoxin and was antagonized by coperfusion with 5-HT<sub>2A</sub> antagonists. These investigators hypothesized that activation of 5-HT<sub>2A</sub> receptors within the nucleus accumbens can enhance DA transmission.

In another microdialysis study in rats, intrastriatal basal DA efflux was significantly enhanced by DOI, whereas infusion of the 5-HT<sub>2A</sub> antagonist SR 46349B had no effect (Lucas & Spampinato, 2000). The effect of DOI on basal DA efflux was not blocked by SR 46349B but was attenuated by the 5-HT<sub>2B/2C</sub> antagonist SB 206553. Although DOI enhancement of basal DA was not blocked by the 5-HT<sub>2A</sub> antagonist, haloperidol-stimulated DA efflux was reduced by both SR 46349B and ritanserin. Conversely, the effect of haloperidol was potentiated when DOI was coperfused with SB 206553. In addition, haloperidol-stimulated DOPAC (the DA metabolite 3,4-dihydroxyphenylacetic acid) overflow was reduced by SR 46349B and potentiated by the combination of SB 206553 with DOI. The authors concluded that striatal 5-HT<sub>2A</sub> receptors mediated activation of DA synthesis and positively modulated DA outflow only under activated conditions.

Similarly, systemic administration of DOI to freely moving rats dose-dependently increased dialysate levels of DA and NE in the frontal cortex. This effect was abolished by the selective 5-HT<sub>2A</sub> antagonist M100907, which by itself did not change DA or NE levels. In contrast, the selective 5-HT<sub>2B/2C</sub> antagonist SB 206553 potentiated the effect of DOI. The authors concluded that 5-HT<sub>2A</sub> receptors exert a phasic, facilitatory influence on cortical levels of DA and NE, whereas 5-HT<sub>2C</sub> receptors exert an inhibitory effect.

Finally, in healthy human volunteers, PET has been used to study the possible role of DA in the effects of psilocybin. Administration of an effective dose of psilocybin, which lacks significant affinity for DA receptors, led to significantly decreased binding of the DA D<sub>2</sub> antagonist [<sup>11</sup>C]raclopride in both caudate nucleus and putamen, a finding that would be consistent with an increase in extracellular DA, which then displaced the antagonist (Vollenweider et al., 1999).

**4.3.4.4. Serotonin<sub>2A</sub> receptor activation alters gene expression.** Nearly all studies of hallucinogens at the cellular or molecular level have focused on acute pharmacological responses, including phenomena such as receptor trafficking, desensitization, ability to alter signaling pathways, etc. Intracellular signaling, however, can also influence gene expression (Dragunow et al., 1989), which can lead to changes in neuronal function. Apparently, long-term expression changes may serve as the basis for understanding why a very small percentage of users suffer long-term adverse sequelae following hallucinogen use. Although at first it may be difficult to understand how the reversible acute receptor effects of

hallucinogens could precipitate mental illness, there may be a small population of individuals particularly sensitive to gene expression changes in which the alterations could tip the balance toward the development of long-lasting psychiatric disorders. Persistent alterations in gene expression might also be important as an underlying component of HPPD (discussed earlier).

The earliest report of a genomic response to stimulation of the 5-HT<sub>2A</sub> receptor appeared in 1993 (Leslie et al., 1993). Those workers used immunocytochemistry to observe localized increased expression of the immediate-early gene *c-fos* in response to systemic administration of 2 or 8 mg/kg of the hallucinogenic amphetamine DOI. All of the brain regions examined where *c-fos* expression increased were known to have a high density of 5-HT<sub>2A</sub> receptors particularly in layer Va of the primary SSC. Pretreatment with the 5-HT<sub>2A</sub> antagonist ritanserin completely blocked *c-fos* expression.

A subsequent report by Tilakaratne and Friedman (1996) employed Northern analysis to study 5-HT agonist-induced expression changes in the immediate-early gene *c-fos* as well as two other immediate-early genes, *ngflc* and *tisl*. The response either to the 5-HT<sub>1A</sub> agonist 8-OH-DPAT or DOI was studied in four different regions of rat brain. For the study of 5-HT<sub>2A</sub>-mediated gene expression changes, they administered DOI at a dose of 4 mg/kg i.p. and examined selected brain regions 30 and 90 min after drug administration. Although expression changes were modest or nonsignificant at the 30 min time point, at 90 min, marked increases in expression of *c-fos* and *ngflc* were observed in cortex, hippocampus, and cerebellum, with no changes seen in the striatum. Significantly increased *tisl* expression was confined to the cortex and cerebellum. There were no DOI-induced expression changes in any of the three genes in the striatum. Similar to the earlier study by Leslie et al. (1993), prior treatment with the 5-HT<sub>2A</sub> antagonist ketanserin completely abolished all DOI-induced gene stimulation.

Pei et al. (2000) studied the effect of DOI on expression of an effector intermediate early gene, *arc* (activity-regulated, cytoskeletal-associated protein). *Arc* and its protein product are localized within neuronal dendrites, enabling local synthesis of the *arc* protein in response to synaptic activity. In this study, 0.2, 1, and 2 mg/kg of DOI was administered and rats were sacrificed 2 hr later. Using *in situ* hybridization, it was shown that DOI produced dose-related increases in *arc* mRNA in cortical regions and in striatum. Significant increases were measured in the orbital cortex and cingulate cortex even at the lowest 0.2 mg/kg dose. The effect on *arc* expression was completely blocked by the 5-HT<sub>2A</sub> antagonist ketanserin.

A limitation of these early studies was the use of immunocytochemistry or Northern analysis to measure expression changes, where specific reagents must be used to observe effects on a particular predetermined gene of interest. Recently, the much more powerful technique of

microarray analysis has been applied as a general screen to identify changes in gene expression induced by LSD. In the first study (Nichols & Sanders-Bush, 2002), LSD (1 mg/kg i.p.) administration to rats led to gene expression changes measured at 90 min after drug administration. RNA from the PFC of rat brain was analyzed with the Affymetrix U34A rat genomic array, which represents nearly one-fourth of the predicted genome. Similar to the studies with DOI discussed earlier, LSD increased expression of the immediate-early genes *c-fos* and *arc*. In addition, five more LSD responding genes were identified in PFC and were verified using RNase protection assays. Those genes included serum glucocorticoid kinase (*sgk*),  $I\kappa\beta\alpha$ , neuron-derived orphan receptor 1 (*Nor1*), *ania3*, and *krox-20*. These workers noted the relatively small number of genes identified as well as the relatively small increases in gene expression (generally two-fold or less) and suggested the possibility that relatively minor changes in cellular physiology may lead to marked changes in cognition. Among the genes identified, they call particular attention to *arc*, also studied by Pei et al. (2000), where LSD induced a robust five-fold expression increase in PFC. Furthermore, the authors noted that the increase in *ania3* is intriguing in light of studies showing a role for glutamate in the actions of hallucinogens because *ania3* is involved in glutamate signaling.

In a subsequent paper, Nichols et al. (2003) examined time course and dose-response effects of the genes identified in their previous study. In addition, they employed 5-HT<sub>1A</sub> and 5-HT<sub>2A</sub> antagonists to identify the relevant receptors activated by LSD that mediated gene expression changes in PFC. Most transcripts showed maximal expression at about 90 min after LSD but some, such as *c-fos*, were significantly stimulated as early as 45 min after drug. These increases had returned to baseline values by 5 hr, except for *Nor1*, which remained maximally elevated even 5 hr after LSD administration. Dose-response studies showed that many genes had significant increases in expression following much lower doses of LSD. The 5-HT<sub>1A</sub> antagonist WAY 100635 failed to antagonize any of the increases and actually potentiated the increased expression of  $I\kappa\beta$ . WAY 100635 given alone, however, led to increased expression of *arc* and *Nor1*. The highly 5-HT<sub>2A</sub>-selective antagonist M100907 blocked the increase of all of the transcripts except for *sgk* and  $I\kappa\beta$ , which also were not affected by WAY 100635. The authors note that most of the genes whose expression is altered by LSD are thought to be involved in the process of synaptic plasticity.

Recently, Gonzalez-Maeso et al. (2003) have reported gene expression profiles that distinguish drug-specific patterns of gene expression for hallucinogenic and nonhallucinogenic 5-HT<sub>2A</sub> agonists. Initially, they quantified the concentration-dependent gene expression changes in response to various agonists in HEK293 cells stably expressing the human 5-HT<sub>2A</sub> receptor. They then applied the method to the in vivo analysis of gene expression changes in response to the hallucinogens DOI and LSD and the

nonhallucinogenic ergoline lisuride in mouse SSC. They also used a 5-HT<sub>2A</sub> receptor null-mutant (knockout) mouse to verify that the changes were dependent on the 5-HT<sub>2A</sub> receptor. Three genes were identified whose expression was increased by both LSD and DOI but not by lisuride: *egr-1* > *egr-2* > *period-1*. The greatest change was seen in *egr-1*, early growth response protein 1, which encodes a zinc-finger transcription factor. *egr-1* links cellular signaling cascades with changes in the gene expression pattern and numerous biological functions have been attributed to it (Liu et al., 1996). Both DOI and LSD increased expression of *egr-2*, also known as *krox-20*, which was identified in earlier LSD gene expression studies by Nichols and Sanders-Bush (2002). The third transcript whose expression was increased by the hallucinogens but not by lisuride was *period-1*, a circadian rhythm-related gene (Cermakian et al., 2001). Both Nichols and Sanders-Bush (2002) and Gonzalez-Maeso et al. (2003) identified increased expression of  $I\kappa\beta\alpha$ , although in the latter study, its expression was also increased by the nonhallucinogenic lisuride. Furthermore, expression of this gene was also increased in 5-HT<sub>2A</sub> receptor null mice, indicating mediation by another type of receptor.

It will be most interesting to see follow-up work along these lines. Gene expression changes in response to the powerful hallucinogen LSD may help to identify any number of cellular components and processes that are important to CNS function. It seems possible that a search for homologous overexpressed gene products in schizophrenia brains may be a productive avenue to determine whether hallucinogens have cellular actions in common with schizophrenia or other psychiatric disorders.

#### 4.4. Are other receptors important to the actions of hallucinogens?

Although the widespread consensus is that activation of the 5-HT<sub>2A</sub> receptor is the essential pharmacological component in the actions of hallucinogens, it is still possible that interactions with other CNS receptors may modulate the overall psychopharmacology. For example, there are specific compounds that are classified as hallucinogens, such as 3,4-methylenedioxyamphetamine (MDA), that have unique psychopharmacology (Nichols et al., 1975; Anderson et al., 1978; Johnson et al., 1986; Nichols & Oberlander, 1989; Nash et al., 1994; Nichols, 1994). In a compound such as MDA, not only are 5-HT<sub>2A/2C</sub> receptors activated but the molecule is also a substrate for the monoamine uptake carriers and has a profound effect on presynaptic release of 5-HT, DA, and NE. Although it has “hallucinogenic” properties, it also has unique psychopharmacology, producing enhanced feelings of closeness and emotional warmth among users. One might therefore reasonably expect that other CNS receptors where the affinity of the receptor for the hallucinogen molecule was in a relevant physiological range might participate in modulating the effects of the



drug. There are several candidate receptors that can be identified, and these will be briefly discussed.

#### 4.4.1. A role for the serotonin<sub>2C</sub> receptor subtype

As discussed earlier, there is compelling evidence that the most salient feature of the introceptive cue of hallucinogens in rats is produced by stimulation of the 5-HT<sub>2A</sub> receptor. In addition, the effects of psilocybin in man are blocked by 5-HT<sub>2A</sub> antagonists (Vollenweider et al., 1998). These data all strongly support the hypothesis that activation of the 5-HT<sub>2A</sub> receptor is the key component of hallucinogen action in man. It is still possible, however, that activation of the 5-HT<sub>2C</sub> receptor may play a role in the overall intoxication process in man. The reason for this is simple: there is no known hallucinogenic agent that has selectivity for the 5-HT<sub>2A</sub> receptor over the 5-HT<sub>2C</sub> receptor. Indeed, most of the more potent compounds that have recently been discovered with LSD-like effects in rats are actually slightly more selective for the 5-HT<sub>2C</sub> receptor (Parker et al., 1998; Chambers et al., 2001). Thus, activation of the 5-HT<sub>2A</sub> receptor may be a necessary but not sufficient pharmacological event. Because the discriminative stimulus of hallucinogens in rats is mediated by activation of the 5-HT<sub>2A</sub> receptor, antagonism of the 5-HT<sub>2C</sub> or other monoamine receptors that might modulate hallucinogen-induced mood changes in humans would be predicted to have no effect in rat behavior unless that receptor modulates the strength of the 5-HT<sub>2A</sub> cue. These speculations ultimately cannot be tested until clinical trials are carried out in man with a highly 5-HT<sub>2A</sub>-selective agonist yet to be discovered.

The possible significance of the 5-HT<sub>2C</sub> receptor in the action of hallucinogens generally has not been appreciated probably due to the lack of agonist ligands specific for this subtype as well as a perception by many that this receptor is primarily localized only in the choroid plexus. Pompeiano et al. (1994), using *in situ* hybridization histochemistry, have shown, however, that the 5-HT<sub>2C</sub> receptor subtype is a principal 5-HT receptor in the rat brain. They observed high levels of mRNA for the 5-HT<sub>2A</sub> receptor in only a few brain areas, particularly PFC, whereas 5-HT<sub>2C</sub> receptor mRNA was expressed at high levels in many brain regions other than choroid plexus. Both 5-HT<sub>2A</sub> and 5-HT<sub>2C</sub> receptor mRNAs were expressed in distinct but overlapping brain areas.

The role of the 5-HT<sub>2C</sub> receptor may be particularly relevant for lisuride, an ergoline with structural similarities to LSD that is generally considered to be nonhallucinogenic in man. Fiorella et al. (1995c) have reexamined the stimulus properties of lisuride and provided evidence that lisuride substitution in hallucinogen-trained rats is mediated by stimulation of 5-HT<sub>2A</sub> receptors. In addition, lisuride is known to suppress the firing of dorsal raphe cells, as does LSD (Rogawski & Aghajanian, 1979), an action that can be ascribed to its potent 5-HT<sub>1A</sub> agonist activity (Marona-Lewicka et al., 2002). Further, both lisuride and LSD are DA D<sub>2</sub> agonists. In cloned rat receptors, LSD and lisuride

have comparable affinities and efficacies as weak partial agonists in activating the inositol phosphate signaling system (Egan et al., 1998). Hence, lisuride appears to possess the pharmacological components believed necessary for hallucinogenic effects in man. Nevertheless, in primary culture of cells from rat choroid plexus that express the native 5-HT<sub>2C</sub> receptor, lisuride is an antagonist of the effect of 5-HT, whereas known hallucinogens are potent 5-HT<sub>2C</sub> agonists (Burriss et al., 1991; Sanders-Bush & Breeding, 1991), thus providing at least some evidence that an agonist action at 5-HT<sub>2C</sub> receptors might be relevant to the effects of hallucinogens (Sanders-Bush, 1994).

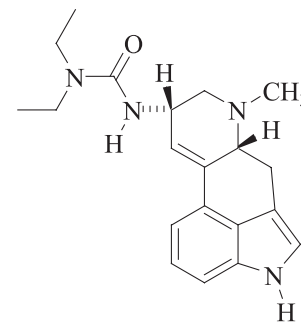

Lisuride

Additional supporting animal data have been reported by Fiorella et al. (1995b) who observed that PCPA depletion of central 5-HT resulted in supersensitivity to the stimulus effects of LSD in rats. Although PCPA had no effect on the maximal level of PI hydrolysis mediated by 5-HT<sub>2A</sub> receptors, the maximal PI hydrolysis in response to 5-HT<sub>2C</sub> receptor stimulation was increased by 46%. It has also been reported that humans are more sensitive to the effects of LSD following treatment with reserpine (Resnick et al., 1965), a regimen that would deplete CNS 5-HT (among other effects). It seems possible, as Burriss et al. (1991) have suggested, that stimulation of both 5-HT<sub>2A</sub> and 5-HT<sub>2C</sub> receptors may be required for hallucinogenic activity. As noted above, therefore, the present data would be consistent with the hypothesis that stimulation of the 5-HT<sub>2A</sub> receptor may be a necessary but not sufficient condition for hallucinogenesis in man. This issue is not likely to be finally resolved until a hallucinogen analogue is discovered and tested in man that possesses selective 5-HT<sub>2A</sub> agonist effects but lacks any action at the 5-HT<sub>2C</sub> receptor. Alternatively, clinical studies of the effect of coadministration of one of the presently available 5-HT<sub>2A/2C</sub> nonselective hallucinogens with a selective 5-HT<sub>2C</sub> antagonist might also provide an answer to this question.

#### 4.4.2. Is the serotonin<sub>1A</sub> receptor important?

As noted in an earlier section, the earliest hypothesis for the mechanism of action of hallucinogens at the cellular level was based on a series of electrophysiological studies



carried out by George Aghajanian and his colleagues. Those experiments showed that administration of LSD, psilocybin, DMT, and 5-MeO-DMT caused a reduction in the firing rate of cells in the dorsal raphe nucleus (Aghajanian et al., 1968, 1970; Aghajanian & Haigler, 1975; deMontigny & Aghajanian, 1977). These observations led to the hypothesis that this pharmacological action might be the underlying mechanism for hallucinogenesis (Aghajanian & Haigler, 1975). Such an explanation was interesting because ascending brainstem systems (such as the serotonergic projections arising from the raphe) modulate neural activity in thalamocortical circuits in a nonspecific or global manner.

This hypothesis could not, however, be extended to the phenethylamine hallucinogens when it was discovered that direct iontophoresis of mescaline into the raphe did not produce similar inhibition of unit activity (Haigler & Aghajanian, 1973). We now know that LSD and the tryptamines have high affinity (and usually high intrinsic activity) at 5-HT<sub>1A</sub> receptors but that the phenethylamine-type hallucinogens do not. Immunohistochemical studies have shown that 5-HT<sub>1A</sub> receptors in the midbrain raphe nuclei are almost exclusively localized on the cell membranes of 5-HT neurons (Sotelo et al., 1990) and agonist drugs at this 5-HT<sub>1A</sub> autoreceptor strongly inhibit central 5-HT neuron activity (Williams et al., 1988). The failure of mescaline or related phenethylamines to suppress raphe firing following direct application can now be understood because these molecules lack significant affinity for 5-HT<sub>1A</sub> receptors (Titeler et al., 1988).

In addition to functioning as somatodendritic autoreceptors in the raphe, postsynaptic 5-HT<sub>1A</sub> receptors are also localized in other brain regions. Their highest density is found in limbic regions of the brain such as the hippocampus (Hamon et al., 1990), areas where emotion and affect would be modified by drug interaction. Early autoradiographic studies showed the presence of 5-HT<sub>1A</sub> receptors in layer V of rat PFC (Glaser et al., 1985; Pazos & Palacios, 1985), and neurons in the human neocortex contain mRNA for the 5-HT<sub>1A</sub> receptor, with pyramidal cells in layer III more heavily labeled than those in layer V (Burnet et al., 1995). In addition, it recently has been shown that 5-HT<sub>1A</sub> receptors are colocalized with 5-HT<sub>2A</sub> receptors on cortical pyramidal cells (Martin-Ruiz et al., 2001), where the two receptor types have opposing effects (Araneda & Andrade, 1991).

LSD has high affinity for 5-HT<sub>1A</sub> receptors as do potent tryptamine hallucinogens such as 5-MeO-DMT and psilocin (McKenna et al., 1990; Blair et al., 2000). LSD is a full agonist at central 5-HT<sub>1A</sub> receptors linked to inhibition of adenylate cyclase (De Vivo & Maayani, 1986). Deliganis et al. (1991) reported that DMT affinity for 5-HT<sub>1A</sub> receptors ( $K_i = 130$  nM) was reduced ( $K_i = 464$  nM) by addition of guanyl nucleotides, suggesting that DMT was an agonist. This hypothesis was confirmed when these workers found that DMT was equally efficacious to the 5-HT<sub>1A</sub> agonist 8-OH-DPAT in inhibiting forskolin-stimulated cAMP forma-

tion in rat hippocampal homogenate. DMT also enhances the acoustic startle response in rats (Davis & Sheard, 1974), an effect now attributed to 5-HT<sub>1A</sub> receptor activation (Nanry & Tilson, 1989). The closely related *N,N*-diethyltryptamine (DET) is also a full agonist in inhibiting forskolin-stimulated cAMP production in cloned human 5-HT<sub>1A</sub> receptors expressed in Chinese hamster ovary cells (Blair et al., 2000). Similarly, 5-MeO-DMT is a full agonist at 5-HT<sub>1A</sub> receptors (Dumuis et al., 1988; Blair et al., 2000).

There also are data suggesting that the 5-HT<sub>1A</sub> effects of LSD may be detectable at least in some animal behavioral assays. Drug discrimination studies in pigeons suggest that LSD may induce 5-HT<sub>1A</sub> receptor-mediated effects (Walker et al., 1991; Yamamoto et al., 1991). The selective 5-HT<sub>1A</sub> receptor agonist 8-OH-DPAT mimicked LSD in rats trained to discriminate 0.16 mg/kg of LSD from saline (Winter & Rabin, 1988; Meert et al., 1990) but LSD only partially mimicked 8-OH-DPAT in rats trained to discriminate the latter agent (Cunningham & Appel, 1987).

As noted earlier, Nielsen (1985) reported that ketanserin and pirenperone failed to block the LSD cue in LSD-trained monkeys. Further, although mescaline also failed to substitute for LSD in these monkeys, substitution did occur with 5-MeO-DMT, a mixed 5-HT<sub>2A/2C/1A</sub> agonist. These results, and others, prompted Nielsen to conclude that there might be a “preferential role for 5-HT<sub>1</sub> sites in mediating the LSD stimulus effect.” Although previous studies, cited earlier, are consistent with the conclusion that the nature of the LSD cue in rats is expressed by 5-HT<sub>2A</sub> receptor activation, it may be that the strength of this cue can be modulated by effects of LSD at 5-HT<sub>1A</sub> or at other monoamine neurotransmitter receptors (e.g., Marona-Lewicka & Nichols, 1995).

The 5-HT<sub>1A</sub> agonist 8-OH-DPAT inhibits DOI-induced head twitch in rats (Arnt & Hyttel, 1989; Berendsen & Broekkamp, 1990; Berendsen, 1991; Willins & Meltzer, 1997). Schreiber et al. (1995) replicated this finding and also reported that the 5-HT<sub>1A</sub> antagonist (–)-tertatolol antagonized the ability of 8-OH-DPAT to block the DOI-induced head twitch. These latter workers concluded that activation of 5-HT<sub>1A</sub> receptors inhibited functional effects mediated by 5-HT<sub>2A</sub> receptors. This reasoning is consistent with a variety of other studies suggesting functional interactions between these two receptor types in the modulation of various behaviors (Backus et al., 1990; Berendsen & Broekkamp, 1990; Darmani et al., 1990; Yocca et al., 1990).

There is also a substantial body of evidence to show functional interactions between 5-HT<sub>1A</sub> and 5-HT<sub>2A</sub> receptors. For example, 5-HT<sub>1A</sub> agonists may produce behavioral effects *in vivo* similar to those seen after administration of 5-HT<sub>2</sub> antagonists (e.g., Arnt & Hyttel, 1989). Further, the behavioral syndrome induced by 5-MeO-DMT can be stereoselectively antagonized by (–)-pindolol or propranolol (Lucki et al., 1984; Tricklebank et al., 1985). In addition, an early study by Dixon (1968) showed that propranolol could block the disruptive behavior induced

by LSD in rats. At the time, this finding was related to a possible involvement of  $\beta$ -adrenergic receptors. In view of present knowledge, however, this result may have been a consequence of 5-HT<sub>1A</sub> receptor antagonism, a pharmacological property of propranolol that was unknown at the time. Conversely, Backus et al. (1990) reported that 5-HT<sub>2</sub> antagonists enhanced the behavioral syndrome induced by 8-OH-DPAT, 5-MeO-DMT, or the partial 5-HT<sub>1A</sub> agonist gepirone.

Ogren and Fuxe (1989) blocked head twitches induced by the hallucinogenic amphetamine DOM by i.c.v. administration of galanin, a 28-amino acid peptide that is thought to modulate 5-HT function throughout the CNS through activation of galanin receptors. Galanin has an inhibitory postsynaptic effect on 5-HT neurons in the dorsal raphe, causing hyperpolarization through a potassium channel (Xu et al., 1998), and is thought to have actions synergistic with 5-HT<sub>1A</sub> receptor activation (Hedlund & Fuxe, 1996). Galanin blockade of DOM-induced head twitches would thus also be consistent with a functional interaction between 5-HT<sub>1A</sub> and 5-HT<sub>2A</sub> receptors.

In the rat mPFC, iontophoresis of the selective 5-HT<sub>1A</sub> receptor agonist 8-OH-DPAT produced a current-dependent suppression of the basal firing rate of spontaneously active cells (Ashby et al., 1994). Iontophoretic or systemic administration of a nonselective 5-HT<sub>2A/2C</sub> or a selective 5-HT<sub>2A</sub> receptor antagonist significantly potentiated and prolonged the suppressant effect of 8-OH-DPAT. Conversely, iontophoresis of a low current of DOI potentiated the excitation induced by the iontophoresis of L-glutamate on quiescent mPFC cells.

Similarly, bath administration of 5-HT produced two distinct responses in layer V pyramidal cells of slices of rat mPFC (Araneda & Andrade, 1991). The initial response was a membrane hyperpolarization mediated by activation of 5-HT<sub>1A</sub> receptors. The second response to 5-HT was 5-HT<sub>2A</sub> receptor-mediated membrane depolarization, the replacement of the afterhyperpolarization that follows a burst of spikes in these cells by a slow depolarizing afterpotential, and a decrease in spike frequency accommodation. These latter effects were mimicked by DOB and blocked by ketanserin or a low concentration of spiperone.

Although 5-HT<sub>1A</sub> and 5-HT<sub>2A</sub> receptors mediate opposing effects on membrane excitability, most pyramidal neurons appear to express both receptor subtypes on their membrane surface (Martin-Ruiz et al., 2001). Araneda and Andrade (1991) reported that coactivation of both receptor subtypes resulted in a selective enhancement of responses to strong excitatory stimuli with little effect on weaker stimuli. The nature and origins of the afferents providing activation of 5-HT receptors mediating such opposite effects on membrane excitability in the same cell would provide a mechanism by which 5-HT could regulate how pyramidal neurons encode incoming excitatory stimuli.

Although the original observation that tryptamine hallucinogens suppress raphe cell activity by a direct effect was

not acceptable as a basis for the mechanism of action, it still seems likely that this phenomenon may be relevant, because phenethylamine hallucinogens do suppress firing in a subset of raphe cells apparently by an indirect GABA-mediated mechanism (Liu et al., 2000; Martin-Ruiz et al., 2001). Because the raphe nuclei are part of the brainstem reticular activating system, believed to be essential for maintaining the state of consciousness (Tononi & Edelman, 1998), it would be surprising if suppressed firing of these cells did not lead to neurological sequelae. In addition, projections from the dorsal and median raphe are the source of 5-HT axons in the cortex and thus are ultimately responsible for activation of both 5-HT<sub>1A</sub> and 5-HT<sub>2A</sub> receptors that are localized on cortical neurons.

What are the clinical consequences of 5-HT<sub>1A</sub> agonist activity in tryptamine hallucinogens? Data are lacking that might clarify this issue, with the exception of a study by Strassman (1996) where prior administration of the 5-HT<sub>1A</sub> antagonist pindolol markedly potentiated the effect of a subhallucinogenic dose of DMT fumarate. One might offer the speculative hypothesis that tryptamine hallucinogens with a significant agonist action at 5-HT<sub>1A</sub> receptors may elicit subtle qualitative effects that distinguish them from phenethylamine type hallucinogens, a quality that is sometimes anecdotally reported by recreational users. Although Wolbach et al. (1962) have reported that the psychopharmacological effects of psilocybin, LSD, and mescaline were virtually indistinguishable in humans, there have been no controlled studies to compare any of these three classical agents with newer phenethylamine hallucinogens that are more selective for the 5-HT<sub>2A/2C</sub> receptors.

As an interesting aside, noted in the previous section, there has been much controversy over the years as to why lisuride, a structural analogue of LSD, is not hallucinogenic (see, e.g., Egan et al., 1998). It is known, however, that lisuride is an extremely potent ( $K_i = 0.2$  nM,  $EC_{50} = 0.6$  nM) 5-HT<sub>1A</sub> receptor agonist (Marona-Lewicka et al., 2002). Based on the observation that 5-HT<sub>1A</sub> receptors are localized on cortical neurons (Martin-Ruiz et al., 2001) and have effects opposite to 5-HT<sub>2A</sub> receptor activation (Araneda & Andrade, 1991), one could speculate that the lack of hallucinogenic activity for lisuride may be due to an overriding stimulation of inhibitory cortical 5-HT<sub>1A</sub> receptors relative to a much weaker effect on excitatory cortical 5-HT<sub>2A</sub> receptors.

#### 4.4.3. Possible potentiating effects of interactions at other receptor subtypes

In the study by Fiorella et al. (1995a), only 56% of the variability in the potency of a given antagonist to block the interoceptive cue produced by LSD could be accounted for by 5-HT<sub>2A</sub> affinity alone. Further, except for pirenperone, all of the antagonists tested in that study were more potent in blocking responding elicited by (–)-DOM in LSD-trained rats than in blocking the responding to LSD itself. Although the essential nature of the LSD cue in rats appears to be

expressed through 5-HT<sub>2A</sub> receptor activation, this cue may be modulated by effects of LSD at other monoamine receptors. These ancillary interactions could be important, particularly in conferring the extraordinarily high in vivo potency possessed by LSD. The affinity of LSD for the 5-HT<sub>2A</sub> and 5-HT<sub>2C</sub> receptors is not significantly different from that of phenethylamine compounds such as DOB or DOI. Similarly, the hydrophobicity of LSD is also of the same magnitude as these amphetamine derivatives (Nichols et al., 1977). Nevertheless, the in vivo potency of LSD is at least one order of magnitude greater than for the most potent phenethylamines.

These facts would seem to suggest that some other pharmacological property of LSD may be potentiating its effects. It is difficult to know what this action might be, however, because LSD binds with high affinity to a variety of monoamine receptors, including 5-HT<sub>1A/1B/1D</sub>, 5-HT<sub>2A/2C</sub>, 5-HT<sub>5A</sub>, 5-HT<sub>6</sub>, and 5-HT<sub>7</sub>, D<sub>1</sub> and D<sub>2</sub> DA receptors, and  $\alpha_1$ - and  $\alpha_2$ -adrenergic receptors (Creese et al., 1975; Burt et al., 1976; U'prichard et al., 1977; Meibach et al., 1980; Leysen, 1985; Hoyer, 1988; Marona-Lewicka & Nichols, 1995; Watts et al., 1995; Nichols et al., 2002; Glennon, 2003). By contrast, phenethylamines such as DOM lack affinity for nearly all of these receptors (Leysen et al., 1989) and have high affinity only for the 5-HT<sub>2A</sub> and 5-HT<sub>2C</sub> receptors (Glennon et al., 1984a; Titeler et al., 1988). Which of these other sites, if any, might be responsible for synergism with 5-HT<sub>2A</sub> agonism? It seems unlikely that the 5-HT<sub>1A</sub> agonist of effect of LSD could be responsible for its remarkable potency, because the tryptamines in general (e.g., DMT and psilocin) possess 5-HT<sub>2A/2C</sub> and 5-HT<sub>1A</sub> affinities comparable to LSD but are a good deal less behaviorally potent.

Although there is no evidence to suggest that the interaction with other 5-HT<sub>1</sub> subtypes is responsible for potentiation, these cannot now be ruled out as possibilities. Further, we know almost nothing about the functional significance of 5-HT<sub>5A</sub> (Glennon, 2003), 5-HT<sub>6</sub> (Sebben et al., 1994; Boess et al., 1997, 1998), or 5-HT<sub>7</sub> (Carter et al., 1995) receptors, where LSD also has high affinity.

LSD also has modest affinity for  $\alpha_2$ -adrenergic receptors. It has been shown that stimulation of  $\alpha_2$ -adrenoceptors by clonidine potentiated the stimulus properties of LSD in the 2-lever drug discrimination paradigm (Marona-Lewicka & Nichols, 1995). Activation of  $\alpha_2$ -adrenergic receptors could be a possible potentiating interaction, although the 37 nM affinity of LSD for [<sup>3</sup>H]clonidine-labeled  $\alpha_2$  receptors is not as great as at many other monoamine receptors.

The most intriguing possibility for a potentiating effect arises from the DA properties of LSD. Although the simple tryptamines or the substituted phenethylamines lack affinity for DA receptors (e.g., Whitaker & Seeman, 1977), LSD has high affinity at both D<sub>1</sub> and D<sub>2</sub> DA receptors (Watts et al., 1995). The affinity of LSD for D<sub>2</sub> receptors ( $K_{0.5} = 6.4$  nM) is certainly in a range where receptor activation could occur at behaviorally relevant doses. The DA D<sub>1</sub> affinity of LSD

( $K_{0.5} = 27$  nM) is somewhat lower, similar to the affinity of LSD at  $\alpha_2$  receptors, but is still relevant at the peak plasma concentration of 10–20 nM (Aghajanian & Bing, 1964; Hawks & Chiang, 1986).

A very early study by Diab et al. (1971) used autoradiography with [<sup>3</sup>H]LSD to show binding in several brain regions, including the caudate nucleus. Somewhat later, autoradiography using [<sup>125</sup>I]-2-iodoLSD showed that this ligand could be used to label both 5-HT<sub>2A/2C</sub> and DA D<sub>2</sub> receptors in rat (Nakada et al., 1984), bovine (Hartig et al., 1985a), and mouse brain (Hartig et al., 1985b). Similarly, autoradiography in rat brain with the same radioligand showed highest binding density in the caudate nucleus and nucleus accumbens, whereas [<sup>125</sup>I]-DOI had much lower binding in those regions (McKenna & Saavedra, 1987). This finding is consistent with the high DA receptor density in these structures and the lack of DA receptor affinity for phenethylamine hallucinogens. Binding of [<sup>125</sup>I]-labeled 2-iodoLSD and DOI in rat brain had some overlapping regions, but in other areas, binding profiles differed markedly (McKenna et al., 1989b). Furthermore, unlabeled DOI was unable to displace a significant amount of [<sup>125</sup>I]-2-iodoLSD from DA brain areas such as the caudate.

A sufficient number of reports have been published to establish firmly that LSD has significant DA effects in a variety of preparations (Pieri et al., 1974; Von Hungen et al., 1974; Creese et al., 1975; Hungen et al., 1975; Kelly, 1975; Kelly & Iversen, 1975; Prada et al., 1975; Spano et al., 1975, 1976; Bockaert et al., 1976; Burt et al., 1976; Nichols, 1976; Antkiewicz-Michaluk et al., 1997; Meltzer et al., 1977; Ahn & Makman, 1979). The possibility of a DA D<sub>2</sub>-potentiating effect of LSD is also strengthened by the finding of Giacomelli et al. (1998) that concentrations of LSD from 10<sup>-13</sup> to 10<sup>-10</sup> M, 10–1000-fold lower than those required for a direct effect, potentiated the direct inhibition of 0.1–1.0 nM DA on prolactin secretion in isolated pituitary lactotrophs.

More recently, using the drug discrimination assay in rats, the nature of the discriminative cue of LSD has been discovered to be time dependent (Marona-Lewicka & Nichols, 2002). When LSD is administered to rats 15–30 min prior to testing, as is well documented, the discriminative cue is mediated by activation of 5-HT<sub>2A</sub> receptors. When, however, the LSD pretreatment time is extended to 90 min, the discriminative cue is mediated through a DA D<sub>2</sub>-like receptor. Drugs that activate the 5-HT<sub>2A</sub> receptor no longer substitute in these “LSD-90” animals; rather, DA D<sub>2</sub>-like agonists such as apomorphine fully substitute, and this cue is blocked by D<sub>2</sub> antagonists such as haloperidol. This effect is not seen in DOI-trained rats, where the cue is mediated through 5-HT<sub>2A</sub> receptors irrespective of the pretreatment time. The most likely explanation for this finding is that LSD has significant affinity for DA receptors, whereas none of the other hallucinogens possess that pharmacology.

Although a potentiating effect of D<sub>2</sub> receptor stimulation has not been extensively investigated for hallucinogens,



risperidone, a mixed 5-HT<sub>2</sub> and D<sub>2</sub> antagonist, was more potent in antagonizing the discriminative cue of LSD in rats than ritanserin, a pure 5-HT<sub>2A/2C</sub> antagonist (Meert et al., 1989). Further, Schreiber et al. (1995) reported that the DOI HTR in rats, in addition to being antagonized by 5-HT<sub>2A</sub> antagonists, was also potently blocked by both D<sub>1</sub> and D<sub>2</sub> DA antagonists. In addition, stimulation of the 5-HT<sub>2A</sub> receptor can enhance DA function (see, e.g., Huang & Nichols, 1993; Ichikawa & Meltzer, 1995).

There is a large body of evidence now developing on the interaction between DA D<sub>2</sub> and 5-HT<sub>2A</sub> receptors, with much of the focus being on the development of atypical antipsychotic agents (Meltzer, 1991). Although a consideration of those data is beyond the scope of this review, the possibility that DA D<sub>2</sub> receptor stimulation may potentiate 5-HT<sub>2A</sub> agonism seems to be an interesting area for further study and would lead the investigation of hallucinogens full circle, back to the premise that they may be useful tools for investigating schizophrenia and psychosis.

## 5. Clinical relevance of serotonin<sub>2A</sub> receptors

There were numerous clinical studies of hallucinogens in the 1950s and 1960s, mostly with LSD, with literally thousands of subjects, but those efforts ceased by about 1970, with the last reports of U.S. work published in 1973 (Grob et al., 1998). In general, hallucinogens are now viewed as a closed chapter in psychiatry research. The early clinical studies were generally focused on studying the effects of LSD either as a “psychotomimetic” (i.e., producing a model psychosis) or as an adjunct to therapy for the treatment of disorders such as sexual dysfunction and drug or alcohol abuse.

In addition to LSD, there was limited study of the potential medical value of two other hallucinogens. *N,N*-dipropyltryptamine (DPT) was studied in the treatment of alcoholism (Grof et al., 1973b), and 3,4-methylenedioxyamphetamine (MDA) was used in a “neurotic” outpatient population (Yensen et al., 1976).

Unfortunately, the imperfect quality of most of the early clinical studies, especially the lack of adequate controls, would render them unacceptable by present-day standards. Thus, much of the discussion that follows in this section is given more to indicate the variety of possibilities there were examined than as any endorsement of therapeutic efficacy.

Because hallucinogens powerfully affect all of the mental functions associated with consciousness, including cognition, mood, perception, self-control, and somatic awareness (Freedman, 1968), it should not be surprising that today we find a resurgence of interest in the 5-HT<sub>2A</sub> receptor for its importance in a variety of psychiatric disorders as well as in various cognitive functions. Clinical studies recently have been initiated in the United States with DMT and psilocybin and in Europe with mescaline and psilocybin. These naturally occurring hallucinogens all have a long and well-

documented history of safety and use in native populations that allowed these studies to proceed without the extensive preclinical toxicology data that are normally required for clinical work. The clinical studies of DMT were also prompted by the fact that this substance is found naturally in mammalian brain and it might therefore be an endogenous psychotogen or psychosis-producing substance. Although LSD is much more potent than any of these other three agents, the notoriety and negative societal associations attached to that drug have so far discouraged clinicians from attempting to implement new human studies of this hallucinogen.

There are three principal areas where clinical studies of hallucinogens have been carried out. The first involves a comparison of the effects of hallucinogens with the symptoms of acute psychosis. Indeed, more than 50 years ago, Osmond and Smythies (1952) stated that it had “been known for 50 years that mescaline...produces symptoms almost identical with schizophrenia.” Although it is beyond the scope of this review to discuss the role of the 5-HT<sub>2A</sub> receptor in psychiatric disorders, it is essential to mention that in recent years this receptor has gained tremendous importance as a potential therapeutic target for various psychiatric disorders such as schizophrenia and depression (De Angelis, 2002). For example, there is extensive evidence for a decrease in the density of cortical 5-HT<sub>2A</sub> receptors in schizophrenia, an effect that is particularly notable in the dorsolateral PFC (Dean, 2003). Further, it is now widely believed that 5-HT<sub>2A</sub> receptor antagonism may be a key pharmacological feature of atypical antipsychotic drugs (Meltzer et al., 1989; Huttunen, 1995; Lieberman et al., 1998; Meltzer, 1999) and administration of the atypical antipsychotic agent clozapine to rats decreased 5-HT<sub>2A</sub> mRNA and [<sup>3</sup>H]ketanserin binding in frontal cortex, whereas 5-HT<sub>1A</sub> and 5-HT<sub>2C</sub> mRNA remained unchanged (Burnet et al., 1996).

One operational measure of the sensorimotor gating or filtering deficits that are suggested to contribute to the cognitive disorganization in schizophrenia is a deficit in habituation and prepulse inhibition (PPI) of startle responses (Geyer, 1998). In rats, 5-HT<sub>2A</sub> agonists disrupt PPI, mimicking the PPI deficit seen in schizophrenia patients. Hallucinogens such as LSD (Braff & Geyer, 1980) and mescaline or other phenethylamine hallucinogens (Wing et al., 1990) impair habituation to tactile startle in rats (Geyer & Tapson, 1988) and the effect is mediated by 5-HT<sub>2A</sub> receptors (Davis et al., 1986; Padich et al., 1996). A study of the effect of psilocybin on PPI in humans, however, gave results different from rat studies. In a double-blind, placebo-controlled study with 12 subjects, psilocybin increased PPI and had no clear effect on habituation in a subset of the subjects (Gouzoulis-Mayfrank et al., 1998a).

From discussion in the earlier sections, it seems clear that hallucinogens induce glutamate release in PFC, and this action appears to be a common feature of both “psychotomimetic” noncompetitive NMDA antagonists such as ket-



amine and PCP and classical hallucinogenic drugs (Aghajanian & Marek, 1999c). There is now an extensive literature on the similarities between effects of drugs such as PCP and ketamine and the symptoms of psychosis (see, e.g., reviews by Jentsch & Roth, 1999; Sams-Dodd, 1999). These similarities have led to suggestions that the effects of hallucinogens resemble the symptoms of acute rather than chronic schizophrenia (Vollenweider et al., 1997b; Vollenweider, 1998). A hyperfrontal metabolic pattern also occurs in humans following administration of subanesthetic doses of the noncompetitive NMDA antagonist ketamine (Vollenweider et al., 1997a) and it has been hypothesized that hallucinogenic effects of drugs may arise, at least in part, from their common capacity to disrupt thalamo-cortical gating of external and internal information to the cortex (Vollenweider & Geyer, 2001).

Although the clinical effects of classical LSD-like hallucinogens and NMDA antagonists such as PCP appear to be somewhat different, some overlap in behavioral pharmacology can be seen in rodents. For example, discriminative stimulus effects of 5-HT<sub>2A</sub> receptor agonists can be potentiated by pretreatment with noncompetitive NMDA glutamate receptor antagonists. In rats trained to discriminate the phenethylamine hallucinogen DOM from saline, pretreatment with PCP shifted the DOM dose-response curve to the left (Winter et al., 2000a). When a small dose of DOM that by itself gave only 32% DOM-appropriate responding was combined with a range of doses of the NMDA antagonists PCP, dizocilpine, and ketamine, DOM-appropriate responding increased to maxima of 73%, 84%, and 79%, respectively. When given alone, PCP, dizocilpine, and ketamine elicited only a small percentage of DOM-appropriate responding.

There are two other broad research areas where there is clinical interest in hallucinogens. The first arises from a continuing belief that hallucinogens may possess medical utility in treating certain psychiatric disorders. The second area of interest that is emerging is their value as research tools for cognitive neuroscience. The following sections will highlight examples of both of these directions.

### 5.1. *Lysergic acid diethylamide treatment in terminal illness*

Of all the proposed medical indications for hallucinogens, one of the more interesting and well-documented uses, particularly for LSD, was in the treatment of terminal patients. Kast and Collins (1964) originally reported that LSD had an analgesic effect in dying patients that far outlasted its acute psychological effects. Their initial observation was that patients for whom this effect occurred seemed to have changed their attitudes toward death. Later studies led Kast (1966, 1970) to the conclusion that LSD treatment resulted in improved psychological adjustment in dying patients, made them more responsive to their families and environments, and enhanced their ability to enjoy everyday life.

In later studies at the Spring Grove State Hospital in Maryland, improvement was found in about two-thirds of terminal cancer patients who had received LSD, including improved mood, reduced anxiety and fear of death, and reduction in the amount of pain-relieving medication required (Pahnke et al., 1969; Grof et al., 1973a; Kurland, 1985). Half of these patients had dramatic improvement, and those who had the most profound experiences derived the most benefit (Pahnke et al., 1970). Unfortunately, these studies ended with the media attention, recreational use, and greatly restricted access to these drugs that occurred in the late 1960s and early 1970s. Recently, efforts have begun to reexamine this potentially important medical benefit of hallucinogens (C. Grob, personal communication; see also <http://www.heffter.org>).

### 5.2. *Treatment of alcoholism and substance abuse*

Of the early attempts to employ hallucinogens in therapy, especially LSD, treatment of alcoholism was one of the most extensively explored, with the first alcoholic patients being treated in Canada in 1953 (Hoffer, 1967; Kurland et al., 1967). The group at the Maryland State Hospital also employed a tryptamine hallucinogen DPT as a potential adjunct to therapy for alcoholism (Grof et al., 1973b). Alcoholism and alcohol abuse rank among the top three psychiatric disorders in the United States and are associated with significant medical and economic consequences. Furthermore, there were many potential treatment candidates, many of whom had failed in previous therapy attempts. Clinical trials in this population were envisioned to be relatively straightforward because few chronic alcoholics were expected to recover spontaneously, and an easily measured end point was thought to be simple: reduction in drinking. Thus, the treatment of alcoholism with hallucinogens was an attractive use for early clinicians (and if it worked would be extremely important today).

The original motivation for using a hallucinogen in the treatment of alcoholism was based on speculation that the effects of LSD might be similar to delirium tremens, the negative consequences of which might help to deter alcohol use. Unfortunately, the question of whether LSD treatment is effective for alcoholism was never convincingly answered. For a complete discussion of this topic, the reader is referred to the excellent and comprehensive analysis provided by Mangini (1998). As noted in that review, the results remain inconclusive because of differences in treatment procedures, theoretical backgrounds, biases and beliefs, and definitions of terms that existed among the various research teams that conducted research. This situation was not unique to studies that employed hallucinogens, however, because uncontrolled studies and post hoc definitions of success were commonplace in psychiatric research in the 1950s.

Based on an exhaustive review of that literature, Mangini (1998) concludes, “Despite the confusion about the

efficacy of LSD treatment occasioned by the limitations of previous studies, the possibility that LSD could be useful in the treatment of alcoholism remains engaging. Many possible constructions of the findings of historic LSD research have been left unexplored, and many aspects of the data remain unevaluated.” What we may conclude from the studies, and Mangini’s analysis, is that a reevaluation of the use of hallucinogens as components of a comprehensive program to treat alcoholism and substance abuse may be worthwhile.

The situation is very similar with respect to early studies carried out to examine the possibility that hallucinogens might be useful treatments for dependence on heroin or other addicting drugs. That is, poor designs, lack of controls, etc., failed to resolve the question of whether therapy with hallucinogens might lead to long-term abstinence. Halpern (1996) discusses several studies where there were hints in the data that hallucinogens appeared to possess some utility. More recently, he has described two anecdotal case studies from his own practice where two patients successfully used hallucinogens to control addiction to heroin and sedative hypnotics (Halpern, 2003). Based on his reviews of the literature, he concludes that hallucinogens deserve closer scrutiny and that there may indeed be a role for these agents in treating drug dependence.

### 5.3. Obsessive-compulsive disorder

Obsessive-compulsive disorder (OCD) is a debilitating condition with a lifetime prevalence of 2–3% (Regier et al., 1988). Savage et al. (1962) provided the earliest report of efficacy for a hallucinogen in OCD, where after two doses of LSD, a patient who suffered from depression and violent obsessive sexual thoughts experienced dramatic and permanent improvement. A later case report appeared where a patient had suffered from severe obsessive thoughts and fear of contamination. After treatment with LSD on a weekly basis for 15 months without any concomitant psychotherapy, the symptoms began to resolve, and three years after the treatment, the patient was completely symptom free and functioning at a high level both professionally and personally (Brandrup & Vanggaard, 1977).

Hanes (1996) published a case report of a patient with body dysmorphic disorder whose symptoms improved markedly on several occasions when he had ingested psilocybin-containing fungi. Leonard and Rapoport (1987) published the case of an adolescent with OCD who had taken LSD more than 100 times, and during the experience, his “obsessive thoughts would be worse for 1 hr followed by total remission for 4–5 hr.” Psilocybin mushrooms or mescaline had the same effect. Additional recent anecdotal studies have provided further evidence that use of hallucinogens may alleviate symptoms of OCD (Moreno & Delgado, 1997; Delgado & Moreno, 1998).

It is currently believed that serotonergic systems play an important role in OCD, but the specific receptors involved

have not been clearly identified. Although there has been discussion that 5-HT<sub>2C</sub> receptors may be important, both agonists and antagonists for that receptor type produce and exacerbate symptoms of OCD (see Chou-Green et al., 2003, and references therein). The above anecdotal reports of long-term remission of OCD symptoms might be more suggestive of hallucinogen-induced 5-HT<sub>2A</sub> receptor down-regulation. Because of the relative lack of efficacy of current therapies, the treatment of OCD with hallucinogens would seem to be an indication deserving of much more extensive research.

### 5.4. Clinical studies of *N,N*-dimethyltryptamine

The first clinical studies of a hallucinogen after a 20-year hiatus of human research were carried out by Dr. Rick Strassman at the University of New Mexico (Strassman & Qualls, 1994; Strassman et al., 1994, 1996; Strassman, 1996). Although DMT is a somewhat obscure hallucinogen, it is distributed widely throughout the plant kingdom. DMT is also a component of several psychoactive preparations used by native cultures, particularly in South America, which have a long history of folkloric use in various ritual contexts (Schultes & Hofmann, 1979).

Apparently, DMT was chosen to reinitiate clinical studies of hallucinogens for several reasons. First, it had previously been studied in man (e.g., Szara et al., 1966, 1970) and it would not be necessary to complete preclinical toxicology prior to initiating human studies. Second, it had been identified as a trace amine in cerebrospinal fluid and thus likely had normal metabolic processes to clear it from the body (Gillin et al., 1976; Corbett et al., 1978; Barker et al., 1981). Third, it has a very short duration of action (less than 1 hr), and clinical experiments can be carried out quickly, whereas LSD and mescaline have a much longer (8–10 hr) duration of action. Finally, because it was relatively obscure, studies of DMT were not as likely to catch the attention of the popular media, focusing unwanted attention into a sensitive area of clinical investigation. Nonetheless, Strassman (1991) details a more than two-year encounter with regulatory hurdles that had to be overcome before clinical studies of DMT could begin.

In their first study, DMT fumarate was given at doses of 0.05–0.4 mg/kg i.v. (Strassman & Qualls, 1994). Doses of 0.2 and 0.4 mg/kg were hallucinogenic, with nearly instantaneous effects that peaked within 2 min and were resolved within 20–30 min. The subjective effects paralleled plasma concentrations of DMT. Pupil diameter, heart rate, mean arterial pressure, and blood levels of corticotropin,  $\beta$ -endorphin, prolactin, and cortisol were significantly elevated, with highest concentrations observed at the peak blood DMT level. Growth hormone and rectal temperature were also significantly increased, but the effects were delayed compared with the other markers.

In a second study, Strassman et al. (1994) reported subjective effects of DMT in humans using a new assess-

ment instrument they had developed, the Hallucinogen Rating Scale (HRS). The effective doses of DMT fumarate, 0.2 and 0.4 mg/kg i.v., produced immediate visual hallucinatory effects, bodily dissociation, marked shifts in mood, and auditory effects in about one-half of the subjects. These effects completely replaced the subjects' ongoing mental experiences but resolved quickly, paralleling the previously reported plasma DMT concentrations. Although the 0.05 and 0.1 mg/kg doses were not hallucinogenic, they did produce emotional and somesthetic effects. The highest dose of 0.4 mg/kg produced extremely intense effects that completely disrupted normal mental function, with most subjects losing all awareness of their bodies or the experimental surroundings.

In a third set of experiments, these investigators studied the ability of DMT to produce tolerance, a phenomenon that occurs with the hallucinogens LSD, mescaline, and psilocybin and discussed earlier in this review. Obviously, tolerance could not be produced by an endogenous hallucinogen because psychosis is a chronic and ongoing process. Four sequential doses of 0.3 mg/kg i.v. DMT fumarate were administered, separated at half-hour intervals. There was no evidence of tolerance to the effects of DMT and the authors note that this finding would be consistent with hypotheses that DMT could occur as an endogenous psychotogen (Strassman et al., 1996).

Finally, the effects of pretreatment with the 5-HT<sub>1A</sub> antagonist pindolol (30 mg p.o.) were assessed using a subhallucinogenic 0.1 mg/kg dose of DMT fumarate. Pindolol pretreatment potentiated the effects of DMT by 2- to 3-fold based on scores on the HRS (Strassman, 1996). This result suggests that 5-HT<sub>1A</sub> receptor blockade can potentiate the effect of 5-HT<sub>2A</sub> receptor stimulation, an effect that would be consistent with the colocalization of both 5-HT<sub>2A</sub> and 5-HT<sub>1A</sub> receptors on cortical pyramidal cells, which have opposing pharmacological effects (Ashby et al., 1994; Martin-Ruiz et al., 2001). A more detailed possible explanation for this observation is presented in the earlier section on the importance of 5-HT<sub>1A</sub> receptors.

### 5.5. *Studies of mescaline*

There have been very few clinical studies employing mescaline. Although mescaline (as the psychoactive component in *peyote*) has a long history of use among Native American populations, it has a long duration of action (10–12 hr) compared with DMT (<1 hr) or psilocybin (4–6 hr). It is, however, orally active, in contrast to DMT, and is also quite easy to synthesize in the laboratory. In the two published reports, mescaline was studied to determine whether its effects were similar to the symptoms of acute psychosis. In normal male volunteers, mescaline produced an acute “psychotic state” 3.5–4 hr after drug administration as measured by the Brief Psychiatric Rating Scale (BPRS) and Paranoid Depression Scale (PDS; Hermle et al., 1992, 1998). Using an instrument to assess ASC,

specific effects of mescaline in the visual system were seen. Neuropsychological actions were studied with a face/non-face decision task with known right hemisphere advantage in which mescaline induced decreased functioning of the right hemisphere.

In a study by Hermle et al. (1998), described earlier, male subjects were given 500 mg mescaline sulfate. Mescaline produced a “hyperfrontal” pattern of increased blood flow, measured with SPECT, which was correlated with mescaline-induced psychological effects assessed using Dittrich's APZ (Oepen et al., 1989; Hermle et al., 1992, 1998).

### 5.6. *Studies of psilocybin*

Psilocybin is the substance that has been most widely employed in recent clinical studies. In contrast to DMT, it is orally active, but its effects are shorter lasting than those of either mescaline or LSD. Most of the studies of psilocybin have been reported by Dr. Franz Vollenweider and his group at the Psychiatric University Hospital of Zurich. Several of his studies were cited earlier, when discussing PET studies of the effects of hallucinogens on cerebral blood flow and brain metabolism.

In clinical studies, psilocybin (15–20 mg depending on body weight) led to significant increases in a variety of psychological symptoms that broadly included disturbances of emotion, sensory perception, thought processes, reality appraisal, and ego function (Vollenweider et al., 1997b). Using Dittrich's APZ questionnaire (Dittrich, 1998) to assess psychological changes, significantly increased subscale measurements included derealization associated with euphoria, exaltation or grandiosity, and an altered sense of time and space. Visual disturbances included effects ranging from illusions to complex scenery hallucinations, synesthesias, and changed meaning of percepts. A third subscale of the APZ measured increases in anxiously experienced loss of ego boundaries, thought disorder, and moderate suspiciousness and paranoid ideation. The effects appeared 20–30 min following p.o. administration and reached a peak after another 50–60 min lasting 1–2 hr (Vollenweider et al., 1998). During the peak period, alteration of sensory perceptions and loosening of ego boundaries were noted. With closed eyes, during the PET scanning period, subjects reported perceptual alterations that included visual disturbances and synesthesias. Directed attention became difficult and subjects lost their interest in the experiment (Vollenweider et al., 1997b). The symptoms had resolved by 5–6 hr.

Spitzer et al. (1996) conducted a double-blind, placebo-controlled study of the effects of psilocybin on semantic and indirect semantic priming. Indirect semantic priming is considered to be an index of spread of activation in semantic networks and this study was designed to measure the spread of activation in semantic networks involved in lexical decision tasks. Although psilocybin had no effect on direct semantic priming, it did increase indirect seman-

tic priming. Their data suggest that psilocybin leads to increased availability of remote associations, thereby bringing cognitive contents to mind that would normally remain inactivated. Psychological performance was generally decreased under the drug, suggesting that the increased indirect priming effect might be due to a decreased capacity to use contextual information for the focusing of semantic processing. Thus, the investigators suggest that subjectively experienced increases in creativity as well as the broadening of consciousness may parallel decreases in objective performance measures. A subsequent study reported a similar although less marked effect of psilocybin on indirect semantic priming (Gouzoulis-Mayfrank et al., 1998b).

Vollenweider et al. (1998) reported a study of the psychological effects of psilocybin as well as its effects on working memory using a memory-guided DRT. Pretreatment with the 5-HT<sub>2A</sub>-selective antagonist ketanserin dose-dependently blocked the psychological effects of psilocybin. Similarly, 1.0 mg of the 5-HT<sub>2A</sub>/D<sub>2</sub> antagonist risperidone completely blocked the effects of psilocybin. By contrast, haloperidol (0.021 mg/kg i.v.) reduced the effect of psilocybin only on one subscale of the APZ and had no effect on visual illusions or hallucinations. Psilocybin also increased reaction time on the DRT. As before, ketanserin and risperidone, but not haloperidol, blocked the increased reaction time on the DRT. None of the antagonists had effects on reaction time when given alone. Interestingly, the rate of correct responses did not differ between any of the treatments.

In a double-blind, placebo-controlled human study with 12 healthy subjects, Gouzoulis-Mayfrank et al. (1998b) assessed the effects of psilocybin on PPI and habituation of the startle reflex. As cited earlier, and in contrast to results from animal studies, psilocybin increased PPI while having no clear effect on habituation. The authors of the study caution that their findings must be considered preliminary because several factors such as small group size, dose regimens, and experimental parameters may influence the results of studies on startle plasticity.

In another study from the same laboratory, Gouzoulis-Mayfrank et al. (2002) used a double-blind, placebo-controlled study in healthy humans to compare psilocybin and placebo on covert orienting of spatial attention. Psilocybin caused an overall slowing of reaction times with particularly slow times in invalid trials at short cue target intervals and failure of response inhibition in valid trials at long cue target intervals for right visual field targets. The authors interpret their result to indicate difficulty in disengaging attention from previously attended locations and reorienting it to targets in the contralateral visual field.

In a study by Umbricht et al. (2003), effects of psilocybin on mismatch negativity (MMN) and an AX continuous performance test (AX-CPT) were studied. Psychological effects were assessed using the BPRS. Deficits

in auditory sensory (echoic) memory are manifested in an impaired ability to match tones following a brief delay seen as an abnormal reduction of an event-related potential (ERP) component that is generated in auditory sensory areas. The ERP component is considered to be an index of echoic memory and is termed MMN and deficits in MMN are a common finding in studies of schizophrenia. Despite a significant increase in the BPRS total score, psilocybin failed to have a significant effect on MMN generation. In the AX-CPT, however, psilocybin led to a significantly decreased hit rate of correct responses and an increase in “false alarms” associated with BX-type sequences. The investigators note that the pattern of psilocybin-induced deficits in AX-CPT was similar to the deficits observed either in subjects given ketamine or in schizophrenic patients (Umbricht et al., 2003, and references therein).

### 5.7. *Effects on cognition and perception: future tools for cognitive neuroscience*

Over the past decade, there has been greatly heightened scientific interest in understanding the nature of consciousness. The recent advent of powerful brain imaging technologies such as functional magnetic resonance imaging (fMRI), PET, etc., has allowed rapid advances in our understanding of the areas of brain responsible for a variety of cognitive tasks. Scientists are less afraid to address the subject, numerous new books and journals have appeared that focus on the study of consciousness, and scientific meetings and congresses are now being held to address the nature of consciousness and how to study it. The field of cognitive neuroscience has addressed the challenge of attempting to understand consciousness and how it arises in the brain. Surely, the most potent drugs known that alter consciousness, the hallucinogens, should play a role in that investigation.

It is now understood that there is no “seat” of consciousness and that consciousness is not a property of a single brain location but more likely arises as the result of dynamic interactions among widely distributed groups of neurons that integrate a very large number of sensory inputs and motor responses occurring in parallel. Edelman (1989) has emphasized that consciousness concerns the rapid integration of signals from a great variety of modalities and submodalities to create a unified, coherent scene or idea. He suggests that the number of possible conscious states is enormous.

As discussed in this review, hallucinogens appear primarily to target sites in PFC and thalamus as well as thalamic afferents to the cortex, and perhaps not surprisingly, it is widely believed that the thalamocortical system is essential for conscious activity (Edelman, 2003). There seems to be a general agreement that the cerebral cortex is essential for determining the contents of consciousness and that, in addition to cortico-cortico interactions, thalamocortical interactions play a special role in the integration of



distributed neural activity across wide cortical regions and in the generation of conscious experience (Tononi & Edelman, 1998).

Based on the convergence of ideas about the substrates of consciousness, and the recognition that hallucinogens target the most important of these, we should expect that hallucinogens, and particularly agonist and antagonist ligands for the 5-HT<sub>2A</sub> receptor, would be useful tools to study consciousness and cognitive function. One may also speculate that it might be possible to develop 5-HT<sub>2A</sub> agonist ligands that are not hallucinogenic, a feature that would make them much more appealing as tools for use in cognitive neuroscience.

Although it is still very early in the game, some indications of the utility of hallucinogens as tools for cognitive neuroscience are already emerging. For example, binocular rivalry is a complex, multilevel process that may help to illuminate cognitive functions such as attention and consciousness (Blake & Logothetis, 2002). The oscillation pattern reported during binocular rivalry is highly correlated in the same individual with the temporal pattern observed in another visual phenomenon known as motion-induced blindness (MIB). A unique deviation from the usual  $\gamma$ -like distribution of intervals was observed for both phenomena in the responses of a subject who subsequently reported having taken LSD 10 hr prior to being tested (Carter & Pettigrew, 2003). The subject showed a highly regular, multimodal response with harmonic intervals that were closely matched for both binocular rivalry and MIB. The authors note that the extraordinary rhythmicity appears to be unique to LSD, because it had not been observed in more than 800 subjects who were previously studied for binocular rivalry. It seems likely that the use of other hallucinogens and dose-response and duration of action studies may offer additional insight into these phenomena and may ultimately be useful in elucidating the underlying neurochemical mechanisms of these cognitive processes.

It also has recently been shown that 5-HT<sub>2A</sub> receptors may play a physiological role in working memory (Williams et al., 2002). Unit cell recording and iontophoresis of 5-HT and several selective 5-HT<sub>2A</sub> antagonists in dorsolateral PFC of rhesus monkeys showed that 5-HT<sub>2A</sub> receptor stimulation leads to an augmentation of spatial tuning in putative prefrontal pyramidal cells. Iontophoresis of the 5-HT<sub>2A</sub> agonist  $\alpha$ -methyl-5-HT using 20–50 nA ejection currents had no effect on most of the cells tested due to tonic activation by endogenous 5-HT. By contrast, 5-HT<sub>2A</sub> receptor antagonists attenuated existent tuning of this cell type in 90% of the cells tested. If, however, the ejection current for  $\alpha$ -methyl-5-HT was increased to >50 nA, these workers noted a profound depression in the delay activity of neurons, suggesting that excessive stimulation of 5-HT<sub>2A</sub> receptors can attenuate memory fields in pyramidal cells.

These workers concluded that 5-HT<sub>2A</sub> receptor stimulation is facilitatory for the mnemonic process occurring in

prefrontal pyramidal cells participating in spatial working memory. The attenuation of memory fields observed with excessive 5-HT<sub>2A</sub> receptor stimulation would be consistent with the demonstration of psilocybin-induced deficits in spatial working memory in humans (Vollenweider et al., 1998; Gouzoulis-Mayfrank et al., 2002). Thus, effective doses of hallucinations may provide excessive stimulation of 5-HT<sub>2A</sub> receptors in PFC, leading to speculation that perhaps subhallucinogenic dosages of 5-HT<sub>2A</sub> agonists might facilitate working memory.

The studies of indirect semantic priming by Spitzer et al. (1996) cited earlier show yet another effect of 5-HT<sub>2A</sub> receptor activation on cognition. No doubt there are many cognitive tasks that will be affected by hallucinogens based on what we are now learning about the anatomical locations and functions of the 5-HT<sub>2A</sub> receptor. Hopefully, the power of these tools will be recognized by a larger number of researchers. Continuing studies of similarities of the effects of hallucinogens with some of the symptoms of acute psychosis may further elucidate details that might ultimately lead to improved therapies for schizophrenia.

There are also some animal data to indicate that 5-HT<sub>2A</sub> receptor function may be important in learning processes. For example, classical conditioning of the rabbit nictitating membrane has been recognized as a reliable measure of associative learning (Gormezano et al., 1983) and has been used by several investigators as a model for examining the neuronal circuitry underlying associative learning (Steinmetz, 2000), as recently reviewed by Harvey (2003). It also has been used to model a variety of clinical states characterized by deficits in associative processes. Hallucinogens such as LSD (Gimpl et al., 1979; Siegel & Freedman, 1988) and DOM (Harvey et al., 1982) have been shown to enhance acquisition of the rabbit nictitating membrane conditioned response (CR) in delay conditioning at micro-mole/kilogram doses that approximately correspond to those that produce psychoactive effects in man. LSD produced a robust enhancement of CR acquisition at conditioned stimulus (CS)-unconditioned stimulus (US) intervals that generated low rates of CR acquisition in vehicle controls (Harvey et al., 1988). Through control experiments, it was determined that the enhancement of CR acquisition promoted by the hallucinogens was due to enhanced associative learning (Harvey et al., 1982; Romano et al., 1991; Romano & Harvey, 1994). Neutral antagonists such as BOL and ketanserin had no effects on associative learning, but several ligands thought to be inverse agonists impaired CR acquisition. Harvey speculates that because the rate of learning is an index of task difficulty, activation of the 5-HT<sub>2A</sub> receptor may have a proportionately greater effect as task difficulty places greater demands on attentional and associative processes. He concludes that the 5-HT<sub>2A</sub> receptor, most likely in PFC and hippocampus, may have an important role in learning and that 5-HT<sub>2A</sub> receptor modulation may lead to profound alterations in cognitive function.

## 6. Conclusions

The tools of today's neuroscience, including in vivo brain imaging technologies, have put a modern face on the hallucinogens. Scientists can no longer see them as "magic" drugs but rather as 5-HT<sub>2A</sub> receptor-specific molecules that affect membrane potentials, neuronal firing frequencies, and neurotransmitter release in particular areas of the brain. One can now begin to speculate in reasonable ways about how these cellular changes transform our perceptions of reality and produce ASC. It is intellectually satisfying, although perhaps not at all surprising, that the neuroanatomical substrates that are apparently most affected by these substances are the ones of most interest to consciousness researchers and cognitive neuroscientists. Very clearly, the substrates in the brain that are affected by hallucinogenic drugs play crucial roles for us as conscious beings in constructing our reality and in defining exactly who we are in relationship to the rest of the world.

One must keep in mind that these substances came to our attention in the first place *only* because of their unique and powerful effects on the human psyche; to forget about the behavioral consequences of hallucinogen-altered neurochemistry is to miss the main point. There will be profound importance in understanding how hallucinogens transduce effects in neuronal systems that provide for the perception of ordinary states of reality under one set of biochemical circumstances but which under another allow what can only be described as an ineffable state of mystical consciousness.

The implications of "stimulating 5-HT<sub>2A</sub> receptors in the brain" go far beyond simply modifying membrane currents and neuronal firing frequencies. If everything that we are and can ever hope to be is somehow inextricably wired into the brain, then molecular tools that modify these circuits in predictable ways will be powerful levers to help us understand better how mind originates from brain states. Make no mistake, neuroscientists today who study depression, schizophrenia, or the palette of other psychiatric disorders do not simply abandon their curiosity when someone asks, "What is consciousness?" Since before recorded history, our species has been on a never-ending quest for meaning in life, and there is no reason why neuroscience should not be a part of that search.

The failure of much of modern science to envision hallucinogens as key ingredients in our efforts to understand the nature of consciousness and the human mind is what has allowed society to view these molecules for so long only as dangerous drugs of abuse. It is quite unfortunate that legal restrictions have kept these extremely interesting substances from receiving more extensive clinical study, but there are hopeful recent signs that this situation may be changing.

Coupling psychological assessments with in vivo brain imaging, as in the work of Franz Vollenweider and his colleagues, Efi Gouzoulis-Mayfrank, and a few others, is a positive move forward toward correlating changes in alterations in mood and thinking with brain function. The recent

discovery by Pettigrew that hallucinogens have dramatic effects on binocular rivalry and MIB promises further insight into other cognitive processes. The effects of hallucinogens on working memory demonstrated by Vollenweider, Gouzoulis-Mayfrank, and others, and clinical studies of the potential medical value of hallucinogens in OCD and terminal patients, may signal that this field is finally reaching a maturity that will lead to many important new discoveries about what is called "the mind" and how the brain generates it.

The philosopher in each of us yearns for greater understanding of who we are and why we are here. Irrational fear of inquiries into the nature of consciousness and conscious experience must be put aside, and hallucinogens should be recognized for what they are: tools that will ultimately help us to understand ourselves. The answers lie in further research for somewhere in the complexity of the brain exists the source of answers to all questions about ourselves. In the coming years, we may look forward to substantial progress in understanding how hallucinogens affect brain function, how those changes alter perception and cognition, and ultimately whether these ancient healing substances have medical value and wisdom to impart to our modern age.

## Acknowledgments

The author gratefully acknowledges more than two decades of continuous support for studies of hallucinogens provided by grant DA02189 from the National Institute on Drug Abuse. The author also thanks Dr. George Aghajanian for helpful discussions concerning electrophysiology studies. Finally, I offer apologies to many outstanding scientists whose complete work I was not able to incorporate into this review; there is such a vast literature on this topic, beginning in the early 1950s, that it would require many volumes adequately to review it all.

## References

- Abi-Saab, W. M., Buser, M., Roth, R. H., & Deutch, A. Y. (1999). 5-HT<sub>2</sub> receptor regulation of extracellular GABA levels in the prefrontal cortex. *Neuropsychopharmacology* 20, 92–96.
- Abraham, H. D., Aldridge, A. M., & Gogia, P. (1996). The psychopharmacology of hallucinogens. *Neuropsychopharmacology* 14, 285–298.
- Acuna-Castillo, C., Villalobos, C., Moya, P. R., Saez, P., Cassels, B. K., & Huidobro-Toro, J.P. (2002). Differences in potency and efficacy of a series of phenylisopropylamine/phenylethylamine pairs at 5-HT(2A) and 5-HT(2C) receptors. *Br J Pharmacol* 136, 510–519.
- Aghajanian, G. K. (1980). Mescaline and LSD facilitate the activation of locus coeruleus neurons by peripheral stimuli. *Brain Res* 186, 492–498.
- Aghajanian, G. K., & Bing, O. H. L. (1964). Persistence of lysergic acid diethylamide in the plasma of human subjects. *Clin Pharmacol Ther* 5, 611–614.
- Aghajanian, G. K., & Haigler, H. J. (1975). Hallucinogenic indoleamines: preferential action upon presynaptic serotonin receptors. *Psychopharmacol Commun* 1, 619–629.
- Aghajanian, G. K., & Marek, G. J. (1997). Serotonin induces excitatory

- postsynaptic potentials in apical dendrites of neocortical pyramidal cells. *Neuropharmacology* 36, 589–599.
- Aghajanian, G. K., & Marek, G. J. (1998). Serotonin 5-HT<sub>2A</sub> receptors enhance asynchronous excitatory transmission in pyramidal cells (layer V) of prefrontal cortex. *Soc Neurosci Abstr* 24, 1366.
- Aghajanian, G. K., & Marek, G. J. (1999a). Serotonin and hallucinogens. *Neuropsychopharmacology* 21, 16S–23S.
- Aghajanian, G. K., & Marek, G. J. (1999b). Serotonin, via 5-HT<sub>2A</sub> receptors, increases EPSCs in layer V pyramidal cells of prefrontal cortex by an asynchronous mode of glutamate release. *Brain Res* 825, 161–171.
- Aghajanian, G. K., & Marek, G. J. (1999c). Serotonin-glutamate interactions: a new target for antipsychotic drugs. *Neuropsychopharmacology* 21, S122–S133.
- Aghajanian, G. K., Foote, W. E., & Sheard, M. H. (1968). Lysergic acid diethylamide: sensitive neuronal units in the midbrain raphe. *Science* 161, 706–708.
- Aghajanian, G. K., Foote, W. E., & Sheard, M. H. (1970). Action of psychotogenic drugs on single midbrain raphe neurons. *J Pharmacol Exp Ther* 171, 178–187.
- Aghajanian, G. K., Haigler, H. J., & Bloom, F. E. (1972). Lysergic acid diethylamide and serotonin: direct actions on serotonin-containing neurons in rat brain. *Life Sci* 11, 615–622.
- Agnati, L. F., Zoli, M., Stromberg, I., & Fuxe, K. (1995). Intercellular communication in the brain: wiring versus volume transmission. *Neuroscience* 69, 711–726.
- Ahn, H. S., & Makman, M. H. (1979). Interaction of LSD and other hallucinogens with dopamine-sensitive adenylate cyclase in primate brain: regional differences. *Brain Res* 162, 77–88.
- Akin, D., Onaran, H. O., & Gurdal, H. (2002). Agonist-directed trafficking explaining the difference between response pattern of naratriptan and sumatriptan in rabbit common carotid artery. *Br J Pharmacol* 136, 171–176.
- Almaula, N., Ebersole, B. J., Ballesteros, J. A., Weinstein, H., & Sealfon, S. C. (1996a). Contribution of a helix 5 locus to selectivity of hallucinogenic and nonhallucinogenic ligands for the human 5-hydroxytryptamine<sub>2A</sub> and 5-hydroxytryptamine<sub>2C</sub> receptors: direct and indirect effects on ligand affinity mediated by the same locus. *Mol Pharmacol* 50, 34–42.
- Almaula, N., Ebersole, B. J., Zhang, D., Weinstein, H., & Sealfon, S. C. (1996b). Mapping the binding site pocket of the serotonin 5-hydroxytryptamine<sub>2A</sub> receptor. Ser3.36(159) provides a second interaction site for the protonated amine of serotonin but not of lysergic acid diethylamide or bufotenin. *J Biol Chem* 271, 14672–14675.
- Anden, N. E., Corrodi, H., Fuxe, K., & Hokfelt, T. (1968). Evidence for a central 5-hydroxytryptamine receptor stimulation by lysergic acid diethylamide. *Br J Pharmacol* 34, 1–7.
- Anden, N. E., Corrodi, H., & Fuxe, K. (1971). Hallucinogenic drugs of the indolealkylamine type and central monoamine neurons. *J Pharmacol Exp Ther* 179, 236–249.
- Anden, N. E., Corrodi, H., Fuxe, K., & Meek, J. L. (1974). Hallucinogenic phenylethylamines: interactions with serotonin turnover and receptors. *Eur J Pharmacol* 25, 176–184.
- Anderson, III, G. M., Braun, G., Braun, U., Nichols, D. E., & Shulgin, A. T. (1978). Absolute configuration and psychotomimetic activity. *NIDA Res Monogr*, 8–15.
- Angrist, B., Rotrosen, J., & Gershon, S. (1974). Assessment of tolerance to the hallucinogenic effects of DOM. *Psychopharmacologia* 36, 203–207.
- Antkiewicz-Michaluk, L., Romanska, I., & Vetulani, J. (1997). Ca<sup>2+</sup> channel blockade prevents lysergic acid diethylamide-induced changes in dopamine and serotonin metabolism. *Eur J Pharmacol* 332, 9–14.
- Aoki, C., Miko, I., Oviedo, H., Mikeladze-Dvali, T., Alexandre, L., Sweeney, N., & Brecht, D.S. (2001). Electron microscopic immunocytochemical detection of PSD-95, PSD-93, SAP-102, and SAP-97 at postsynaptic, presynaptic, and nonsynaptic sites of adult and neonatal rat visual cortex. *Synapse* 40, 239–257.
- Appel, J. B., & Freedman, D. X. (1968). Tolerance and cross-tolerance among psychotomimetic drugs. *Psychopharmacologia* 13, 267–274.
- Araneda, R., & Andrade, R. (1991). 5-hydroxytryptamine 2 and 5-hydroxytryptamine 1A receptors mediate opposing responses on membrane excitability in rat association cortex. *Neuroscience* 40, 399–412.
- Arnt, J., & Hyttel, J. (1989). Facilitation of 8-OHDPAT-induced forepaw treading of rats by the 5-HT<sub>2</sub> agonist DOI. *Eur J Pharmacol* 161, 45–51.
- Arvanov, V. L., Liang, X., Magro, P., Roberts, R., & Wang, R. Y. (1999a). A pre- and postsynaptic modulatory action of 5-HT and the 5-HT<sub>2A,2C</sub> receptor agonist DOB on NMDA-evoked responses in the rat medial prefrontal cortex. *Eur J Neurosci* 11, 2917–2934.
- Arvanov, V. L., Liang, X., Russo, A., & Wang, R. Y. (1999b). LSD and DOB: interaction with 5-HT<sub>2A</sub> receptors to inhibit NMDA receptor-mediated transmission in the rat prefrontal cortex. *Eur J Neurosci* 11, 3064–3072.
- Asanuma, C. (1992). Noradrenergic innervation of the thalamic reticular nucleus: a light and electron microscopic immunohistochemical study in rats. *J Comp Neurol* 319, 299–311.
- Ashby, C. R. Jr., Edwards, E., & Wang, R. Y. (1994). Electrophysiological evidence for a functional interaction between 5-HT<sub>1A</sub> and 5-HT<sub>2A</sub> receptors in the rat medial prefrontal cortex: an iontophoretic study. *Synapse* 17, 173–181.
- Aston-Jones, G., & Bloom, F. E. (1981). Norepinephrine-containing locus coeruleus neurons in behaving rats exhibit pronounced responses to non-noxious environmental stimuli. *J Neurosci* 1, 887–900.
- Aulakh, C. S., Mazzola-Pomietto, P., Hill, J. L., & Murphy, D. L. (1994a). Role of various 5-HT receptor subtypes in mediating neuroendocrine effects of 1-(2,5-dimethoxy-4-methylphenyl)-2-aminopropane (DOM) in rats. *J Pharmacol Exp Ther* 271, 143–148.
- Aulakh, C. S., Mazzola-Pomietto, P., Wozniak, K. M., Hill, J. L., & Murphy, D. L. (1994b). Evidence that 1-(2,5-dimethoxy-4-methylphenyl)-2-aminopropane-induced hypophagia and hyperthermia in rats is mediated by serotonin-2A receptors. *J Pharmacol Exp Ther* 270, 127–132.
- Backus, L. I., Sharp, T., & Grahame-Smith, D. G. (1990). Behavioural evidence for a functional interaction between central 5-HT<sub>2</sub> and 5-HT<sub>1A</sub> receptors. *Br J Pharmacol* 100, 793–799.
- Balestrieri, A., & Fontanari, D. (1959). Acquired and cross tolerance to mescaline, LSD-25, and BOL-148. *Arch Gen Psychiatry* 1, 279–282.
- Bankson, M. G., & Cunningham, K. A. (2001). 3,4-Methylenedioxyamphetamine (MDMA) as a unique model of serotonin receptor function and serotonin-dopamine interactions. *J Pharmacol Exp Ther* 297, 846–852.
- Barfknecht, C. F., & Nichols, D. E. (1972). Effects of S-(+)- and R-(–)-3,4-dimethoxyphenylisopropylamines in the rat. *J Med Chem* 15, 109–110.
- Barker, S. A., Monti, J. A., & Christian, S. T. (1981). N,N-dimethyltryptamine: an endogenous hallucinogen. *Int Rev Neurobiol* 22, 83–110.
- Barr, H. L., Langs, R. J., Holt, R. R., Goldberger, L., & Klein, G. S. (1972). *LSD: Personality and Experience*. New York: Wiley-Interscience.
- Behrendt, R. P. (2003). Hallucinations: synchronisation of thalamocortical gamma oscillations underconstrained by sensory input. *Conscious Cogn* 12, 413–451.
- Beique, J. C., & Andrade, R. (2003). PSD-95 regulates synaptic transmission and plasticity in rat cerebral cortex. *J Physiol* 546, 859–867.
- Berendsen, H. H. G. (1991). Behavioural consequences of selective activation of 5-HT receptor subtypes; possible implications for the mode of action of antidepressants. Ph.D. dissertation, University of Groningen, The Netherlands.
- Berendsen, H. H., & Broekkamp, C. L. (1990). Behavioural evidence for functional interactions between 5-HT-receptor subtypes in rats and mice. *Br J Pharmacol* 101, 667–673.
- Berg, K. A., Clarke, W. P., Sailstad, C., Saltzman, A., & Maayani, S. (1994). Signal transduction differences between 5-hydroxytryptamine type 2A and type 2C receptor systems. *Mol Pharmacol* 46, 477–484.
- Berg, K. A., Maayani, S., Goldfarb, J., & Clarke, W. P. (1998a). Pleiotropic behavior of 5-HT<sub>2A</sub> and 5-HT<sub>2C</sub> receptor agonists. *Ann NY Acad Sci* 861, 104–110.
- Berg, K. A., Maayani, S., Goldfarb, J., Scaramellini, C., Leff, P., & Clarke,



- P. J. (1998b). Effector pathway-dependent relative efficacy at serotonin type 2A and 2C receptors: evidence for agonist-directed trafficking of receptor stimulus. *Mol Pharmacol* 54, 94–104.
- Beyerstein, B. L., Dal Cason, T. A., Franzosa, E. S., Hugel, J., Kalchik, M., Laing, R., Lankin, d., Meyers, J., & Shulgin, A. T. (2003). *Hallucinogens. A Forensic Handbook*. New York: Academic Press.
- Blair, J. B., Kurrasch-Orbaugh, D., Marona-Lewicka, D., Cumbay, M. G., Watts, V. J., Barker, E. L., & Nichols, D. E. (2000). Effect of ring fluorination on the pharmacology of hallucinogenic tryptamines. *J Med Chem* 43, 4701–4710.
- Blake, R., & Logothetis, N. K. (2002). Visual competition. *Nat Rev Neurosci* 3, 13–21.
- Blue, M. E., Yagaloff, K. A., Mamounas, L. A., Hartig, P. R., & Molliver, M. E. (1988). Correspondence between 5-HT<sub>2</sub> receptors and serotonergic axons in rat neocortex. *Brain Res* 453, 315–328.
- Boarder, M. R. (1977). The mode of action of indoleamine and other hallucinogens. *Essays Neurochem Neuropharmacol* 2, 21–48.
- Bockaert, J., Premont, J., Glowinski, J., Thierry, A. M., & Tassin, J. P. (1976). Topographical distribution of dopaminergic innervation and of dopaminergic receptors in the rat striatum: II. Distribution and characteristics of dopamine adenylate cyclase-interaction of D-LSD with dopaminergic receptors. *Brain Res* 107, 301–315.
- Boess, F. G., Monsma Jr., F. J., Meyer, V., Zwingerstein, C., & Sleight, A. J. (1997). Interaction of tryptamine and ergoline compounds with threonine 196 in the ligand binding site of the 5-hydroxytryptamine<sub>6</sub> receptor. *Mol Pharmacol* 52, 515–523.
- Boess, F. G., Monsma Jr., F. J., & Sleight, A.J. (1998). Identification of residues in transmembrane regions III and VI that contribute to the ligand binding site of the serotonin 5-HT<sub>6</sub> receptor. *J Neurochem* 71, 2169–2177.
- Braff, D. L., & Geyer, M. A. (1980). Acute and chronic LSD effects on rat startle: data supporting an LSD-rat model of schizophrenia. *Biol Psychiatry* 15, 909–916.
- Brancheck, T., Adham, N., Macchi, M., Kao, H. T., & Hartig, P. R. (1990). [<sup>3</sup>H]-DOB(4-bromo-2,5-dimethoxyphenylisopropylamine) and [<sup>3</sup>H] ketanserin label two affinity states of the cloned human 5-hydroxytryptamine<sub>2</sub> receptor. *Mol Pharmacol* 38, 604–609.
- Brandrup, E., & Vanggaard, T. (1977). LSD treatment in a severe case of compulsive neurosis. *Acta Psychiatr Scand* 55, 127–141.
- Brawley, P., & Duffield, J.C. (1972). The pharmacology of hallucinogens. *Pharmacol Rev* 24, 31–66.
- Brimblecombe, R. W. (1973). Psychotomimetic drugs: biochemistry and pharmacology. *Adv Drug Res* 7, 165–206.
- Brimblecombe, R. W., & Pinder, R. M. (1975). *Hallucinogenic Agents*. Bristol, UK: Wright-Scientific.
- Brink, C. B. (2002). Protean behavior by agonists: agonist-directed trafficking of receptor signaling. *Trends Pharmacol Sci* 23, 454–455.
- Browne, R. G., & Ho, B. T. (1975). Role of serotonin in the discriminative stimulus properties of mescaline. *Pharmacol Biochem Behav* 3, 429–435.
- Buckholtz, N. S., Freedman, D. X., & Middaugh, L. D. (1985). Daily LSD administration selectively decreases serotonin<sub>2</sub> receptor binding in rat brain. *Eur J Pharmacol* 109, 421–425.
- Buckholtz, N. S., Zhou, D. F., & Freedman, D. X. (1988). Serotonin<sub>2</sub> agonist administration down-regulates rat brain serotonin<sub>2</sub> receptors. *Life Sci* 42, 2439–2445.
- Buckholtz, N. S., Zhou, D. F., Freedman, D. X., & Potter, W. Z. (1990). Lysergic acid diethylamide (LSD) administration selectively downregulates serotonin<sub>2</sub> receptors in rat brain. *Neuropsychopharmacology* 3, 137–148.
- Burnet, P. W., Eastwood, S. L., Lacey, K., & Harrison, P. J. (1995). The distribution of 5-HT<sub>1A</sub> and 5-HT<sub>2A</sub> receptor mRNA in human brain. *Brain Res* 676, 157–168.
- Burnet, P. W., Chen, C. P., McGowan, S., Franklin, M., & Harrison, P. J. (1996). The effects of clozapine and haloperidol on serotonin-1A, -2A and -2C receptor gene expression and serotonin metabolism in the rat forebrain. *Neuroscience* 73, 531–540.
- Burris, K. D., Breeding, M., & Sanders-Bush, E. (1991). (+)Lysergic acid diethylamide, but not its nonhallucinogenic congeners, is a potent serotonin 5HT<sub>1C</sub> receptor agonist. *J Pharmacol Exp Ther* 258, 891–896.
- Burt, D. R., Creese, I., & Snyder, S. H. (1976). Binding interactions of lysergic acid diethylamide and related agents with dopamine receptors in the brain. *Mol Pharmacol* 12, 631–638.
- Callaway, J. C., Raymon, L. P., Hearn, W. L., McKenna, D. J., Grob, C. S., Brito, G. S., & Mash, D. C. (1996). Quantitation of *N,N*-dimethyltryptamine and harmala alkaloids in human plasma after oral dosing with ayahuasca. *J Anal Toxicol* 20, 492–497.
- Carter, O. L., & Pettigrew, J. D. (2003). A common oscillator for perceptual rivalries. *Perception* 32, 295–305.
- Carter, D., Champney, M., Hwang, B., & Eglen, R. M. (1995). Characterization of a postjunctional 5-HT receptor mediating relaxation of guinea-pig isolated ileum. *Eur J Pharmacol* 280, 243–250.
- Cedarbaum, J. M., & Aghajanian, G. K. (1978). Activation of locus coeruleus neurons by peripheral stimuli: modulation by a collateral inhibitory mechanism. *Life Sci* 23, 1383–1392.
- Cerletti, A., & Rothlin, E. (1955). Role of 5-hydroxytryptamine in mental disease and its antagonism to lysergic acid derivatives. *Nature* 176, 785–786.
- Cermakian, N., Monaco, L., Pando, M. P., Dierich, A., & Sassone-Corsi, P. (2001). Altered behavioral rhythms and clock gene expression in mice with a targeted mutation in the Period1 gene. *EMBO J* 20, 3967–3974.
- Chambers, J. J., & Nichols, D. E. (2002). A homology-based model of the human 5-HT<sub>2A</sub> receptor derived from an in silico activated G-protein coupled receptor. *J Comput Aided Mol Des* 16, 511–520.
- Chambers, J. J., Kurrasch-Orbaugh, D. M., Parker, M.A., & Nichols, D. E. (2001). Enantiospecific synthesis and pharmacological evaluation of a series of super-potent, conformationally restricted 5-HT(2A/2C) receptor agonists. *J Med Chem* 44, 1003–1010.
- Chambers, J. J., Parrish, J. C., Jensen, N. H., Kurrasch-Orbaugh, D. M., Marona-Lewicka, D., & Nichols, D. E. (2003). Synthesis and pharmacological characterization of a series of geometrically constrained 5-HT<sub>2A/2C</sub> receptor ligands. *J Med Chem* 46, 3526–3535.
- Chiang, C., & Aston-Jones, G. (1993). A 5-hydroxytryptamine<sub>2</sub> agonist augments gamma-aminobutyric acid and excitatory amino acid inputs to noradrenergic locus coeruleus neurons. *Neuroscience* 54, 409–420.
- Chilcoat, H. D., & Schutz, C. G. (1996). Age-specific patterns of hallucinogen use in the US population: an analysis using generalized additive models. *Drug Alcohol Depend* 43, 143–153.
- Cho, K. O., Hunt, C. A., & Kennedy, M. B. (1992). The rat brain postsynaptic density fraction contains a homolog of the *Drosophila* discs-large tumor suppressor protein. *Neuron* 9, 929–942.
- Cholden, L. S., Kurland, A., & Savage, C. (1955). Clinical reactions and tolerance to LSD in chronic schizophrenia. *J Nerv Ment Dis* 122, 211–221.
- Chou-Green, J. M., Holscher, T. D., Dallman, M. F., & Akana, S.F. (2003). Compulsive behavior in the 5-HT<sub>2C</sub> receptor knockout mouse. *Physiol Behav* 78, 641–649.
- Cohen, S. (1960). Lysergic acid diethylamide: side effects and complications. *J Nerv Ment Dis* 130, 30–40.
- Cohen, S. (1967). Psychotomimetic agents. *Annu Rev Pharmacol* 7, 301–318.
- Colpaert, F. C., & Janssen, P. A. (1983). A characterization of LSD-antagonist effects of pirenperone in the rat. *Neuropharmacology* 22, 1001–1005.
- Colpaert, F. C., Niemegeers, C. J., & Janssen, P. A. (1982). A drug discrimination analysis of lysergic acid diethylamide (LSD): in vivo agonist and antagonist effects of purported 5-hydroxytryptamine antagonists and of pirenperone, a LSD-antagonist. *J Pharmacol Exp Ther* 221, 206–214.
- Commissaris, R. L., Lyness, W. H., Cordon, J. J., Moore, K. E., & Rech, R. H. (1980). Behavioral tolerance to the effects of LSD in the rat. *Subst Alcohol Actions Misuse* 1, 203–207.
- Conn, P. J., & Sanders-Bush, E. (1984). Selective 5HT-2 antagonists inhibit serotonin stimulated phosphatidylinositol metabolism in cerebral cortex. *Neuropharmacology* 23, 993–996.



- Conn, P. J., & Sanders-Bush, E. (1986). Regulation of serotonin-stimulated phosphoinositide hydrolysis: relation to the serotonin 5-HT<sub>2</sub> binding site. *J Neurosci* 6, 3669–3675.
- Corbett, L., Christian, S. T., Morin, R. D., Benington, F., & Smythies, J. R. (1978). Hallucinogenic N-methylated indolealkylamines in the cerebrospinal fluid of psychiatric and control populations. *Br J Psychiatry* 132, 139–144.
- Cornea-Hebert, V., Riad, M., Wu, C., Singh, S. K., & Descarries, L. (1999). Cellular and subcellular distribution of the serotonin 5-HT<sub>2A</sub> receptor in the central nervous system of adult rat. *J Comp Neurol* 409, 187–209.
- Creese, I., Burt, D. R., & Synder, S. H. (1975). The dopamine receptor: differential binding of D-LSD and related agents to agonist and antagonist states. *Life Sci* 17, 1715–1719.
- Crick, F. (1984). Function of the thalamic reticular complex: the searchlight hypothesis. *Proc Natl Acad Sci USA* 81, 4586–4590.
- Cunningham, K. A., & Appel, J. B. (1987). Neuropharmacological reassessment of the discriminative stimulus properties of D-lysergic acid diethylamide (LSD). *Psychopharmacology (Berl)* 91, 67–73.
- Cussac, D., Newman-Tancredi, A., Duqueyroux, D., Pasteau, V., & Millan, M. J. (2002). Differential activation of G<sub>q/11</sub> and G<sub>i(3)</sub> proteins at 5-hydroxytryptamine(2C) receptors revealed by antibody capture assays: influence of receptor reserve and relationship to agonist-directed trafficking. *Mol Pharmacol* 62, 578–589.
- Cyr, M., Landry, M., & Di Paolo, T. (2000). Modulation by estrogen-receptor directed drugs of 5-hydroxytryptamine-2A receptors in rat brain. *Neuropsychopharmacology* 23, 69–78.
- Dall’Olio, R., Gaggi, R., Bonfante, V., & Gandolfi, O. (1999). The non-competitive NMDA receptor blocker dizocilpine potentiates serotonergic function. *Behav Pharmacol* 10, 63–71.
- Darmani, N. A., Martin, B. R., Pandey, U., & Glennon, R. A. (1990). Do functional relationships exist between 5-HT<sub>1A</sub> and 5-HT<sub>2</sub> receptors? *Pharmacol Biochem Behav* 36, 901–906.
- Darvesh, A. S., & Gudelsky, G. A. (2003). Activation of 5-HT<sub>2</sub> receptors induces glycogenolysis in the rat brain. *Eur J Pharmacol* 464, 135–140.
- Davies, M. F., Deisz, R. A., Prince, D. A., & Peroutka, S. J. (1987). Two distinct effects of 5-hydroxytryptamine on single cortical neurons. *Brain Res* 423, 347–352.
- Davis, M., & Sheard, M. H. (1974). Biphasic dose-response effects of N-N-dimethyltryptamine on the rat startle reflex. *Pharmacol Biochem Behav* 2, 827–829.
- Davis, M., Cassella, J. V., Wrean, W. H., & Kehne, J. H. (1986). Serotonin receptor subtype agonists: differential effects on sensorimotor reactivity measured with acoustic startle. *Psychopharmacol Bull* 22, 837–843.
- De Angelis, L. (2002). 5-HT<sub>2A</sub> antagonists in psychiatric disorders. *Curr Opin Investig Drugs* 3, 106–112.
- de Saint, H. Z., Orosco, M., Rouch, C., Python, A., & Nicolaidis, S. (2000). Neuromodulation of the prefrontal cortex during sleep: a microdialysis study in rats. *NeuroReport* 11, 1619–1624.
- De Vivo, M., & Maayani, S. (1986). Characterization of the 5-hydroxytryptamine<sub>1A</sub> receptor-mediated inhibition of forskolin-stimulated adenylate cyclase activity in guinea pig and rat hippocampal membranes. *J Pharmacol Exp Ther* 238, 248–253.
- Dean, B. (2003). The cortical serotonin<sub>2A</sub> receptor and the pathology of schizophrenia: a likely accomplice. *J Neurochem* 85, 1–13.
- Delgado, P. L., & Moreno, F. A. (1998). Hallucinogens, serotonin and obsessive-compulsive disorder. *J Psychoactive Drugs* 30, 359–366.
- Deliganis, A. V., Pierce, P. A., & Peroutka, S. J. (1991). Differential interactions of dimethyltryptamine (DMT) with 5-HT<sub>1A</sub> and 5-HT<sub>2</sub> receptors. *Biochem Pharmacol* 41, 1739–1744.
- deMontigny, C., & Aghajanian, G. K. (1977). Preferential action of 5-methoxytryptamine and 5-methoxydimethyltryptamine on presynaptic serotonin receptors: a comparative iontophoretic study with LSD and serotonin. *Neuropharmacology* 16, 811–818.
- Diab, I. M., Freedman, D. X., & Roth, L. J. (1971). (<sup>3</sup>H)lysergic acid diethylamide: cellular autoradiographic localization in rat brain. *Science* 173, 1022–1024.
- Diaz, J. L. (1977). Ethnopharmacology of sacred psychoactive plants used by the Indians of Mexico. *Annu Rev Pharmacol Toxicol* 17, 647–675.
- Dittrich, A. (1998). The standardized psychometric assessment of altered states of consciousness (ASCs) in humans. *Pharmacopsychiatry* 31 (Suppl 2), 80–84.
- Dixon, A. K. (1968). Evidence of catecholamine mediation in the “aberrant” behaviour induced by lysergic acid diethylamide (LSD) in the rat. *Experientia* 24, 743–747.
- Dobkin, D. R. (1971). Ayahuasca—the healing vine. *Int J Soc Psychiatry* 17, 256–269.
- Doherty, M. D., & Pickel, V. M. (2000). Ultrastructural localization of the serotonin 2A receptor in dopaminergic neurons in the ventral tegmental area. *Brain Res* 864, 176–185.
- Dragunow, M., Currie, R. W., Faull, R. L., Robertson, H. A., & Jansen, K. (1989). Immediate-early genes, kindling and long-term potentiation. *Neurosci Biobehav Rev* 13, 301–313.
- Dumuis, A., Sebben, M., & Bockaert, J. (1988). Pharmacology of 5-hydroxytryptamine-1A receptors which inhibit cAMP production in hippocampal and cortical neurons in primary culture. *Mol Pharmacol* 33, 178–186.
- Ebersole, B. J., & Sealfon, S. C. (2002). Strategies for mapping the binding site of the serotonin 5-HT<sub>2A</sub> receptor. *Methods Enzymol* 343, 123–136.
- Ebersole, B. J., Visiers, I., Weinstein, H., & Sealfon, S. C. (2003). Molecular basis of partial agonism: orientation of indoleamine ligands in the binding pocket of the human serotonin 5-HT<sub>2A</sub> receptor determines relative efficacy. *Mol Pharmacol* 63, 36–43.
- Edelman, G. M. (1989). *The Remembered Present: A Biological Theory of Consciousness*. New York: Basic Books.
- Edelman, G. M. (2003). Naturalizing consciousness: a theoretical framework. *Proc Natl Acad Sci USA* 100, 5520–5524.
- Egan, C. T., Herrick-Davis, K., Miller, K., Glennon, R. A., & Teitler, M. (1998). Agonist activity of LSD and lisuride at cloned 5HT<sub>2A</sub> and 5HT<sub>2C</sub> receptors. *Psychopharmacology (Berl)* 136, 409–414.
- Engel, G., Muller-Schweinitzer, E., & Palacios, J. M. (1984). 2-[<sup>125</sup>I]odo]LSD, a new ligand for the characterisation and localisation of 5-HT<sub>2</sub> receptors. *Naunyn-Schmiedeberg’s Arch Pharmacol* 325, 328–336.
- Erdtmann-Vourliotis, M., Mayer, P., Riechert, U., & Holtt, V. (1999). Acute injection of drugs with low addictive potential (delta(9)-tetrahydrocannabinol, 3,4-methylenedioxymethamphetamine, lysergic acid diethylamide) causes a much higher c-fos expression in limbic brain areas than highly addicting drugs (cocaine and morphine). *Brain Res Mol Brain Res* 71, 313–324.
- Felder, C. C., Kanterman, R. Y., Ma, A. L., & Axelrod, J. (1990). Serotonin stimulates phospholipase A<sub>2</sub> and the release of arachidonic acid in hippocampal neurons by a type 2 serotonin receptor that is independent of inositolphospholipid hydrolysis. *Proc Natl Acad Sci USA* 87, 2187–2191.
- Fiorella, D., Helsley, S., Lorrain, D. S., Rabin, R. A., & Winter, J. C. (1995a). The role of the 5-HT<sub>2A</sub> and 5-HT<sub>2C</sub> receptors in the stimulus effects of hallucinogenic drugs: III. The mechanistic basis for supersensitivity to the LSD stimulus following serotonin depletion. *Psychopharmacology (Berl)* 121, 364–372.
- Fiorella, D., Rabin, R. A., & Winter, J. C. (1995b). Role of 5-HT<sub>2A</sub> and 5-HT<sub>2C</sub> receptors in the stimulus effects of hallucinogenic drugs: II. reassessment of LSD false positives. *Psychopharmacology (Berl)* 121, 357–363.
- Fiorella, D., Rabin, R. A., & Winter, J. C. (1995c). The role of the 5-HT<sub>2A</sub> and 5-HT<sub>2C</sub> receptors in the stimulus effects of hallucinogenic drugs: I. Antagonist correlation analysis. *Psychopharmacology (Berl)* 121, 347–356.
- Freedman, D. X. (1961). Effects of LSD-25 on brain serotonin. *J Pharmacol Exp Ther* 134, 160–166.
- Freedman, D. X. (1968). On the use and abuse of LSD. *Arch Gen Psychiatry* 18, 330–347.
- Freedman, D. X. (1969). The psychopharmacology of hallucinogenic agents. *Annu Rev Med* 20, 409–418.

- Freedman, D. X., & Boggan, W. O. (1974). Brain serotonin metabolism after tolerance dosage of LSD. *Adv Biochem Psychopharmacol* 10, 151–157.
- Freedman, D. X., Aghajanian, G. K., Ornitz, E. M., & Rosner, B. S. (1958). Patterns of tolerance to lysergic acid diethylamide and mescaline in rats. *Science* 127, 1173–1174.
- Freedman, D. X., Gottlieb, R., & Lovell, R. A. (1970). Psychotomimetic drugs and brain 5-hydroxytryptamine metabolism. *Biochem Pharmacol* 19, 1181–1188.
- Freo, U., Soncrant, T. T., Holloway, H. W., & Rapoport, S. I. (1991). Dose- and time-dependent effects of 1-(2,5-dimethoxy-4-iodophenyl)-2-aminopropane (DOI), a serotonergic 5-HT<sub>2</sub> receptor agonist, on local cerebral glucose metabolism in awake rats. *Brain Res* 541, 63–69.
- Fuller, D. G. (1976). Severe solar maculopathy associated with the use of lysergic acid diethylamide (LSD). *Am J Ophthalmol* 81, 413–416.
- Fuxe, K., Holmstedt, B., & Jonsson, G. (1972). Effects of 5-methoxy-*N,N*-dimethyltryptamine on central monoamine neurons. *Eur J Pharmacol* 19, 25–34.
- Gaddum, J. H. (1953). Antagonism between lysergic acid diethylamide and 5-hydroxytryptamine. *J Physiol* 121, 15.
- Gaddum, J. H., & Hameed, K. A. (1954). Drugs which antagonize 5-hydroxytryptamine. *Br J Pharmacol* 9, 240–248.
- Gallaher, T. K., Chen, K., & Shih, J. C. (1993). Higher affinity of psilocin for human than rat 5-HT<sub>2</sub> receptor indicates binding site structure. *Med Chem Res* 3, 52–66.
- Gatzke, H. D. (1977). The effect of lysergic acid diethylamide (LSD) on the rat cortex. A quantitative autoradiographic study. *Verh Anat Ges*, 163–169.
- Gellman, R. L., & Aghajanian, G. K. (1994). Serotonin<sub>2</sub> receptor-mediated excitation of interneurons in piriform cortex: antagonism by atypical antipsychotic drugs. *Neuroscience* 58, 515–525.
- Gewirtz, J. C., & Marek, G. J. (2000). Behavioral evidence for interactions between a hallucinogenic drug and group II metabotropic glutamate receptors. *Neuropsychopharmacology* 23, 569–576.
- Geyer, M. A. (1998). Behavioral studies of hallucinogenic drugs in animals: implications for schizophrenia research. *Pharmacopsychiatry* 31 (Suppl 2), 73–79.
- Geyer, M. A., & Tapon, G. S. (1988). Habituation of tactile startle is altered by drugs acting on serotonin-2 receptors. *Neuropsychopharmacology* 1, 135–147.
- Giacomelli, S., Palmery, M., Romanelli, L., Cheng, C. Y., & Silvestrini, B. (1998). Lysergic acid diethylamide (LSD) is a partial agonist of D<sub>2</sub> dopaminergic receptors and it potentiates dopamine-mediated prolactin secretion in lactotrophs in vitro. *Life Sci* 63, 215–222.
- Gillin, J. C., Kaplan, J., Stillman, R., & Wyatt, R. J. (1976). The psychedelic model of schizophrenia: the case of *N,N*-dimethyltryptamine. *Am J Psychiatry* 133, 203–208.
- Gimpl, M. P., Gormezano, I., & Harvey, J. A. (1979). Effects of LSD on learning as measured by classical conditioning of the rabbit nictitating membrane response. *J Pharmacol Exp Ther* 208, 330–334.
- Ginzel, K. H., & Mayer-Gross, W. (1956). Prevention of psychological effects of D-lysergic acid diethylamide (LSD 25) by its 2-brom derivative (BOL 148). *Nature* 178, 210.
- Glaser, T., Rath, M., Traber, J., Zilles, K., & Schleicher, A. (1985). Autoradiographic identification and topographical analyses of high affinity serotonin receptor subtypes as a target for the novel putative anxiolytic TVX Q 7821. *Brain Res* 358, 129–136.
- Glennon, R. A. (1989). Stimulus properties of hallucinogenic phenalkylamines and related designer drugs: formulation of structure-activity relationships. *NIDA Res Monogr* 94, 43–67.
- Glennon, R. A. (1999). Arylalkylamine drugs of abuse: an overview of drug discrimination studies. *Pharmacol Biochem Behav* 64, 251–256.
- Glennon, R. A. (2003). Higher-end serotonin receptors: 5-HT(5), 5-HT(6), and 5-HT(7). *J Med Chem* 46, 2795–2812.
- Glennon, R. A., Rosecrans, J. A., & Young, R. (1983a). Drug-induced discrimination: a description of the paradigm and a review of its specific application to the study of hallucinogenic agents. *Med Res Rev* 3, 289–340.
- Glennon, R. A., Young, R., & Jacyno, J. M. (1983b). Indolealkylamine and phenalkylamine hallucinogens. Effect of alpha-methyl and *N*-methyl substituents on behavioral activity. *Biochem Pharmacol* 32, 1267–1273.
- Glennon, R. A., Young, R., & Rosecrans, J. A. (1983c). Antagonism of the effects of the hallucinogen DOM and the purported 5-HT agonist piazine by 5-HT<sub>2</sub> antagonists. *Eur J Pharmacol* 91, 189–196.
- Glennon, R. A., Titeler, M., & McKenney, J. D. (1984a). Evidence for 5-HT<sub>2</sub> involvement in the mechanism of action of hallucinogenic agents. *Life Sci* 35, 2505–2511.
- Glennon, R. A., Young, R., Hauck, A. E., & McKenney, J. D. (1984b). Structure-activity studies on amphetamine analogs using drug discrimination methodology. *Pharmacol Biochem Behav* 21, 895–901.
- Glennon, R. A., Titeler, M., & Young, R. (1986). Structure-activity relationships and mechanism of action of hallucinogenic agents based on drug discrimination and radioligand binding studies. *Psychopharmacol Bull* 22, 953–958.
- Glennon, R. A., Titeler, M., & Lyon, R. A. (1988). A preliminary investigation of the psychoactive agent 4-bromo-2,5-dimethoxyphenethylamine: a potential drug of abuse. *Pharmacol Biochem Behav* 30, 597–601.
- Gogerty, J. H., & Dille, J. M. (1957). Pharmacology of D-lysergic acid morpholide (LSM). *J Pharmacol Exp Ther* 120, 340–348.
- Goldberg, E. (2001). The Executive Brain. Frontal Lobes and the Civilized Mind. New York: Oxford University Press.
- Gomez-Cambronero, J., & Keire, P. (1998). Phospholipase D: a novel major player in signal transduction. *Cell Signal* 10, 387–397.
- Gonzalez-Maeso, J., Yuen, T., Ebersole, B. J., Wurmbach, E., Lira, A., Zhou, M., Weisstaub, N., Hen, R., Gingrich, J. A., & Sealfon, S. C. (2003). Transcriptome fingerprints distinguish hallucinogenic and non-hallucinogenic 5-hydroxytryptamine 2A receptor agonist effects in mouse somatosensory cortex. *J Neurosci* 23, 8836–8843.
- Gormezano, I., Kehoe, E. J., & Marshall, B. (1983). Twenty years of classical conditioning research with the rabbit. In J. M. Sprague, & A. N. Epstein (Eds.), *Progress in Psychobiology and Physiological Psychology* (pp. 197–275). New York: Academic Press.
- Gouzoulis-Mayfrank, E., Heekeren, K., Thelen, B., Lindenblatt, H., Kovar, K. A., Sass, H., & Geyer, M. A. (1998a). Effects of the hallucinogen psilocybin on habituation and prepulse inhibition of the startle reflex in humans. *Behav Pharmacol* 9, 561–566.
- Gouzoulis-Mayfrank, E., Schneider, F., Friedrich, J., Spitzer, M., Thelen, B., & Sass, H. (1998b). Methodological issues of human experimental research with hallucinogens. *Pharmacopsychiatry* 31 (Suppl 2), 114–118.
- Gouzoulis-Mayfrank, E., Schreckenberger, M., Sabri, O., Arming, C., Thelen, B., Spitzer, M., Kovar, K. A., Hermle, L., Bull, U., & Sass, H. (1999). Neurometabolic effects of psilocybin, 3,4-methylenedioxyethylamphetamine (MDE) and D-methamphetamine in healthy volunteers. A double-blind, placebo-controlled PET study with [<sup>18</sup>F]FDG. *Neuropsychopharmacology* 20, 565–581.
- Gouzoulis-Mayfrank, E., Thelen, B., Maier, S., Heekeren, K., Kovar, K. A., Sass, H., & Spitzer, M. (2002). Effects of the hallucinogen psilocybin on covert orienting of visual attention in humans. *Neuropsychobiology* 45, 205–212.
- Gray, J. A., & Roth, B. L. (2001). Paradoxical trafficking and regulation of 5-HT(2A) receptors by agonists and antagonists. *Brain Res Bull* 56, 441–451.
- Gray, J. A., Sheffler, D. J., Bhatnagar, A., Woods, J. A., Hufeisen, S. J., Benovic, J. L., & Roth, B. L. (2001). Cell-type specific effects of endocytosis inhibitors on 5-hydroxytryptamine(2A) receptor desensitization and resensitization reveal an arrestin-, GRK2-, and GRK5-independent mode of regulation in human embryonic kidney 293 cells. *Mol Pharmacol* 60, 1020–1030.
- Gray, J. A., Compton-Toth, B. A., & Roth, B. L. (2003). Identification of two serine residues essential for agonist-induced 5-HT<sub>2A</sub> receptor desensitization. *Biochemistry* 42, 10853–10862.
- Gresch, P. J., Strickland, L. V., & Sanders-Bush, E. (2002). Lysergic acid diethylamide-induced Fos expression in rat brain: role of serotonin-2A receptors. *Neuroscience* 114, 707–713.

- Grob, C. S., McKenna, D. J., Callaway, J. C., Brito, G. S., Neves, E. S., Oberlaender, G., Saide, O. L., Labigalini, E., Tacla, C., Miranda, C. T., Strassman, R. J., & Boone, K. B. (1996). Human psychopharmacology of hoasca, a plant hallucinogen used in ritual context in Brazil. *J Nerv Ment Dis* 184, 86–94.
- Grob, C. S., Greer, G. R., & Mangini, M. (1998). Hallucinogens at the turn of the century: an introduction. *J Psychoactive Drugs* 30, 315–319.
- Grof, S. (1975). Realms of the human unconscious. *Observations from LSD Research*. New York: Viking Press.
- Grof, S., & Grof, C. (1980). *Beyond Death. The Gates of Consciousness*. London: Thames and Hudson.
- Grof, S., Goodman, L. E., Richards, W. A., & Kurland, A. A. (1973a). LSD-assisted psychotherapy in patients with terminal cancer. *Int Pharmacopsychiatry* 8, 129–144.
- Grof, S., Soskin, R. A., Richards, W. A., & Kurland, A. A. (1973b). DPT as an adjunct in psychotherapy of alcoholics. *Int Pharmacopsychiatry* 8, 104–115.
- Haigler, H. J., & Aghajanian, G. K. (1973). Mescaline and LSD: direct and indirect effects on serotonin-containing neurons in brain. *Eur J Pharmacol* 21, 53–60.
- Halpern, J. H. (1996). The use of hallucinogens in the treatment of addiction. *Addict Res* 4, 177–189.
- Halpern, J. H. (2003). Hallucinogens: an update. *Curr Psychiatry Rep* 5, 347–354.
- Halpern, J. H., & Pope Jr., H. G. (1999). Do hallucinogens cause residual neuropsychological toxicity? *Drug Alcohol Depend* 53, 247–256.
- Halpern, J. H., & Pope, H. G. (2003). Hallucinogen persisting perception disorder: what do we know after 50 years? *Drug Alcohol Depend* 69, 109–119.
- Hamada, S., Senzaki, K., Hamaguchi-Hamada, K., Tabuchi, K., Yamamoto, H., Yamamoto, T., Yoshikawa, S., Okano, H., & Okado, N. (1998). Localization of 5-HT<sub>2A</sub> receptor in rat cerebral cortex and olfactory system revealed by immunohistochemistry using two antibodies raised in rabbit and chicken. *Brain Res Mol Brain Res* 54, 199–211.
- Hamon, M., Gozlan, H., El Mestikawy, S., Emerit, M. B., Bolanos, F., & Schechter, L. (1990). The central 5-HT<sub>1A</sub> receptors: pharmacological, biochemical, functional, and regulatory properties. *Ann NY Acad Sci* 600, 114–129.
- Hanes, K. R. (1996). Serotonin, psilocybin, and body dysmorphic disorder: a case report. *J Clin Psychopharmacol* 16, 188–189.
- Hartig, P. R., Evans, M. J., Krohn, A. M., Leder, S. A., Sze, P. C., & Stoffers, D. A. (1985). [<sup>125</sup>I]LSD binding to serotonin and dopamine receptors in bovine caudate membranes. *Neurochem Int* 7, 699–707.
- Hartig, P. R., Scheffel, U., Frost, J. J., & Wagner Jr., H. N. (1985). In vivo binding of [<sup>125</sup>I]-LSD to serotonin 5-HT<sub>2</sub> receptors in mouse brain. *Life Sci* 37, 657–664.
- Harvey, J. A. (2003). Role of the serotonin 5-HT<sub>2A</sub> receptor in learning. *Learn Mem* 10, 355–362.
- Harvey, J. A., Gormezano, I., & Cool, V. A. (1982). Effects of D-lysergic acid diethylamide, D-2-bromolysergic acid diethylamide, DL-2,5-dimethoxy-4-methylamphetamine and D-amphetamine on classical conditioning of the rabbit nictitating membrane response. *J Pharmacol Exp Ther* 221, 289–294.
- Harvey, J. A., Gormezano, I., Cool-Hauser, V. A., & Schindler, C. W. (1988). Effects of LSD on classical conditioning as a function of CS-US interval: relationship to reflex facilitation. *Pharmacol Biochem Behav* 30, 433–441.
- Hasler, F., Bourquin, D., Brenneisen, R., Bar, T., & Vollenweider, F. X. (1997). Determination of psilocin and 4-hydroxyindole-3-acetic acid in plasma by HPLC-ECD and pharmacokinetic profiles of oral and intravenous psilocybin in man. *Pharm Acta Helv* 72, 175–184.
- Hasuo, H., Matsuoka, T., & Akasu, T. (2002). Activation of presynaptic 5-hydroxytryptamine 2A receptors facilitates excitatory synaptic transmission via protein kinase C in the dorsolateral septal nucleus. *J Neurosci* 22, 7509–7517.
- Hawks, R. L., & Chiang, C. N. (1986). *Urine Testing for Drugs of Abuse*. Rockville, MD: Department of Health and Human Services.
- Hedlund, P. B., & Fuxe, K. (1996). Galanin and 5-HT<sub>1A</sub> receptor interactions as an integrative mechanism in 5-HT neurotransmission in the brain. *Ann NY Acad Sci* 780, 193–212.
- Henderson, L. A. (1994). LSD use and LSD users: questions and answers about LSD. In L.A. Henderson, & W.J. Glass (Eds.), *LSD: Still with Us After All These Years* (pp. 77–98). New York: Lexington Books.
- Hermle, L., Funfgeld, M., Oepen, G., Botsch, H., Borchardt, D., Gouzoulis, E., Fehrenbach, R. A., & Spitzer, M. (1992). Mescaline-induced psychopathological, neuropsychological, and neurometabolic effects in normal subjects: experimental psychosis as a tool for psychiatric research. *Biol Psychiatry* 32, 976–991.
- Hermle, L., Gouzoulis-Mayfrank, E., & Spitzer, M. (1998). Blood flow and cerebral laterality in the mescaline model of psychosis. *Pharmacopsychiatry* 31 (Suppl 2), 85–91.
- Hoffer, A. (1967). A program for the treatment of alcoholism: LSD, malvaria and nicotinic acid. In H.A. Abramson (Ed.), *The Use of LSD in Psychotherapy and Alcoholism* (pp. 343–406). Indianapolis: Bobbs-Merrill.
- Hofmann, A. (1979). How LSD originated. *J Psychedelic Drugs* 11, 53–60.
- Hofmann, A. (1994). Notes and documents concerning the discovery of LSD. 1970. *Agents Actions* 43, 79–81.
- Hoffman, A. J., & Nichols, D. E. (1985). Synthesis and LSD-like discriminative stimulus properties in a series of N(6)-alkyl norlysergic acid N,N-diethylamide derivatives. *J Med Chem* 28, 1252–1255.
- Hoffmeister, F. (1975). Negative reinforcing properties of some psychotropic drugs in drug-naive rhesus monkeys. *J Pharmacol Exp Ther* 192, 468–477.
- Hollister, L. E. (1978). Psychotomimetic drugs in man. In L. L. Iversen, S. D. Iversen, & S. H. Snyder (Eds.), *Handbook of Psychopharmacology* (pp. 389–424). New York: Plenum.
- Hollister, L. E. (1984). Effects of hallucinogens in humans. In B. L. Jacobs (Ed.), *Hallucinogens: Neurochemical, Behavioral, and Clinical Perspectives* (pp. 19–33). New York: Raven Press.
- Horita, A. (1963). Some biochemical studies on psilocybin and psilocin. *J Neuropsychiatry* 4, 270.
- Horita, A., & Weber, L. J. (1961). The enzymatic dephosphorylation and oxidation of psilocybin and psilocin by mammalian tissue homogenates. *Biochem Pharmacol* 7, 47–54.
- Hoyer, D. (1988). Functional correlates of serotonin 5-HT<sub>1</sub> recognition sites. *J Recept Res* 8, 59–81.
- Huang, X., & Nichols, D. E. (1993). 5-HT<sub>2</sub> receptor-mediated potentiation of dopamine synthesis and central serotonergic deficits. *Eur J Pharmacol* 238, 291–296.
- Hungen, K. V., Roberts, S., & Hill, D. F. (1975). Interactions between lysergic acid diethylamide and dopamine-sensitive adenylate cyclase systems in rat brain. *Brain Res* 94, 57–66.
- Huttunen, M. (1995). The evolution of the serotonin-dopamine antagonist concept. *J Clin Psychopharmacol* 15, 4S–10S.
- Ichikawa, J., & Meltzer, H. Y. (1995). DOI, a 5-HT<sub>2A/2C</sub> receptor agonist, potentiates amphetamine-induced dopamine release in rat striatum. *Brain Res* 698, 204–208.
- Isbell, H., Belleville, R. E., Fraser, H. F., Wikler, A., & Logan, C. R. (1956). Studies on lysergic acid diethylamide (LSD-25): I. Effects in former morphine addicts and development of tolerance during chronic intoxication. *Arch Neurol Psychiat* 76, 468–478.
- Isbell, H., Miner, E. J., & Logan, C. R. (1959). Relationships of psychotomimetic to anti-serotonin potencies of congeners of lysergic acid diethylamide (LSD-25). *Psychopharmacology (Berl)* 1, 20–28.
- Isbell, H., Wolbach, A. E., Wikler, A., & Miner, E. J. (1961). Cross tolerance between LSD and psilocybin. *Psychopharmacologia (Berl)* 2, 147–159.
- Ismaiel, A. M., De Los, A. J., Teitler, M., Ingher, S., & Glennon, R. A. (1993). Antagonism of 1-(2,5-dimethoxy-4-methylphenyl)-2-aminopropane stimulus with a newly identified 5-HT<sub>2</sub>- versus 5-HT<sub>1C</sub>-selective antagonist. *J Med Chem* 36, 2519–2525.
- Ivins, K. J., & Molinoff, P. B. (1991). Desensitization and down-regulation of 5-HT<sub>2</sub> receptors in P11 cells. *J Pharmacol Exp Ther* 259, 423–429.



- Jacobs, B. L. (1984). *Hallucinogens: Neurochemical, Behavioral, and Clinical Perspectives*. New York: Raven Press.
- Jaffe, J. H. (1985). Drug addiction and drug abuse. In A. G. Gilman, L. S. Rall, T. W. Rall, & F. Murad (Eds.), *Goodman and Gilman's the Pharmacological Basis of Therapeutics* (pp. 532–581). New York: Macmillan.
- Jaffe, J. H. (1990). Drug addiction and drug abuse. In A. G. Goodman, T. W. Rall, A. S. Nies, & P. Taylor (Eds.), *Goodman and Gilman's the Pharmacological Basis of Therapeutics* (pp. 522–573). New York: McGraw-Hill.
- Jakab, R. L., & Goldman-Rakic, P. S. (1998). 5-Hydroxytryptamine<sub>2A</sub> serotonin receptors in the primate cerebral cortex: possible site of action of hallucinogenic and antipsychotic drugs in pyramidal cell apical dendrites. *Proc Natl Acad Sci USA* 95, 735–740.
- Jansson, A., Tinner, B., Bancila, M., Verge, D., Steinbusch, H. W., Agnati, L.F., & Fuxe, K. (2001). Relationships of 5-hydroxytryptamine immunoreactive terminal-like varicosities to 5-hydroxytryptamine-2A receptor-immunoreactive neuronal processes in the rat forebrain. *J Chem Neuroanat* 22, 185–203.
- Jentsch, J. D., & Roth, R. H. (1999). The neuropsychopharmacology of phencyclidine: from NMDA receptor hypofunction to the dopamine hypothesis of schizophrenia. *Neuropsychopharmacology* 20, 201–225.
- Johnson, M. P., Hoffman, A. J., & Nichols, D. E. (1986). Effects of the enantiomers of MDA, MDMA and related analogues on [<sup>3</sup>H]serotonin and [<sup>3</sup>H]dopamine release from superfused rat brain slices. *Eur J Pharmacol* 132, 269–276.
- Johnson, M. P., Audia, J. E., Nissen, J. S., & Nelson, D. L. (1993). N(1)-substituted ergolines and tryptamines show species differences for the agonist-labeled 5-HT<sub>2</sub> receptor. *Eur J Pharmacol* 239, 111–118.
- Johnson, M. P., Loncharich, R. J., Baez, M., & Nelson, D. L. (1994). Species variations in transmembrane region V of the 5-hydroxytryptamine type 2A receptor alter the structure-activity relationship of certain ergolines and tryptamines. *Mol Pharmacol* 45, 277–286.
- Johnson, M. P., Wainscott, D. B., Lucaites, V. L., Baez, M., & Nelson, D. L. (1997). Mutations of transmembrane IV and V serines indicate that all tryptamines do not bind to the rat 5-HT<sub>2A</sub> receptor in the same manner. *Brain Res Mol Brain Res* 49, 1–6.
- Kao, H. T., Adham, N., Olsen, M. A., Weinshank, R. L., Branchek, T. A., & Hartig, P. R. (1992). Site-directed mutagenesis of a single residue changes the binding properties of the serotonin 5-HT<sub>2</sub> receptor from a human to a rat pharmacology. *FEBS Lett* 307, 324–328.
- Kast, E. (1966). LSD and the dying patient. *Chic Med Sch Q* 26, 80–87.
- Kast, E. C. (1970). A concept of death. In B. Aaronson, & H. Osmond (Eds.), *Psychedelics: The Uses and Implications of Hallucinogenic Drugs* (pp. 366–381). Garden City, NY: Anchor Books.
- Kast, E. C., & Collins, V. J. (1964). Lysergic acid diethylamide as an analgesic agent. *Anesth Analg* 43, 285–291.
- Kelly, P. H. (1975). Proceedings: action of LSD on supersensitive mesolimbic dopamine receptors. *Br J Pharmacol* 55, 291P.
- Kelly, P. H., & Iversen, L. L. (1975). LSD as an agonist at mesolimbic dopamine receptors. *Psychopharmacologia* 45, 221–224.
- Kennett, G. A., Wood, M. D., Glen, A., Grewal, S., Forbes, I., Gadre, A., & Blackburn, T. P. (1994). In vivo properties of SB 200646A, a 5-HT<sub>2C/2B</sub> receptor antagonist. *Br J Pharmacol* 111, 797–802.
- Kilts, J. D., Connery, H. S., Arrington, E. G., Lewis, M. M., Lawler, C. P., Oxford, G. S., O'Malley, K. L., Todd, R. D., Blake, B. L., Nichols, D. E., & Mailman, R.B. (2002). Functional selectivity of dopamine receptor agonists: II. Actions of dihydrexidine in D2L receptor-transfected MN9D cells and pituitary lactotrophs. *J Pharmacol Exp Ther* 301, 1179–1189.
- Kim, E., Cho, K. O., Rothschild, A., & Sheng, M. (1996). Heteromultimerization and NMDA receptor-clustering activity of Chapsyn-110, a member of the PSD-95 family of proteins. *Neuron* 17, 103–113.
- Kim, H. S., Park, I. S., & Park, W. K. (1998). NMDA receptor antagonists enhance 5-HT<sub>2</sub> receptor-mediated behavior, head-twitch response, in mice. *Life Sci* 63, 2305–2311.
- Kim, H. S., Park, I. S., Lim, H. K., & Choi, H. S. (1999). NMDA receptor antagonists enhance 5-HT<sub>2</sub> receptor-mediated behavior, head-twitch response, in PCPA-treated mice. *Arch Pharm Res* 22, 113–118.
- Kistner, U., Wenzel, B. M., Veh, R. W., Cases-Langhoff, C., Garner, A. M., Appeltauer, U., Voss, B., Gundelfinger, E. D., & Garner, C. C. (1993). SAP90, a rat presynaptic protein related to the product of the *Drosophila* tumor suppressor gene *dlg-A*. *J Biol Chem* 268, 4580–4583.
- Klodzinska, A., Bijak, M., Tokarski, K., & Pilc, A. (2002). Group II mGlu receptor agonists inhibit behavioural and electrophysiological effects of DOI in mice. *Pharmacol Biochem Behav* 73, 327–332.
- Kornau, H. C., Schenker, L. T., Kennedy, M. B., & Seeburg, P. H. (1995). Domain interaction between NMDA receptor subunits and the postsynaptic density protein PSD-95. *Science* 269, 1737–1740.
- Kornau, H. C., Seeburg, P. H., & Kennedy, M. B. (1997). Interaction of ion channels and receptors with PDZ domain proteins. *Curr Opin Neurobiol* 7, 368–373.
- Krebs-Thomson, K., Paulus, M. P., & Geyer, M. A. (1998). Effects of hallucinogens on locomotor and investigatory activity and patterns: influence of 5-HT<sub>2A</sub> and 5-HT<sub>2C</sub> receptors. *Neuropsychopharmacology* 18, 339–351.
- Kurland, A. A. (1985). LSD in the supportive care of the terminally ill cancer patient. *J Psychoactive Drugs* 17, 279–290.
- Kurland, A. A., Unger, S., Shaffer, J. W., & Savage, C. (1967). Psychedelic therapy utilizing LSD in the treatment of the alcoholic patient: a preliminary report. *Am J Psychiatry* 123, 1202–1209.
- Kurrasch-Orbaugh, D. M., Parrish, J. C., Watts, V. J., & Nichols, D. E. (2003a). A complex signaling cascade links the serotonin<sub>2A</sub> receptor to phospholipase A<sub>2</sub> activation: the involvement of MAP kinases. *J Neurochem* 86, 980–991.
- Kurrasch-Orbaugh, D. M., Watts, V. J., Barker, E. L., & Nichols, D. E. (2003b). Serotonin 5-hydroxytryptamine 2A receptor-coupled phospholipase C and phospholipase A<sub>2</sub> signaling pathways have different receptor reserves. *J Pharmacol Exp Ther* 304, 229–237.
- Lambe, E. K., & Aghajanian, G. K. (2001). The role of Kv1.2-containing potassium channels in serotonin-induced glutamate release from thalamocortical terminals in rat frontal cortex. *J Neurosci* 21, 9955–9963.
- Leonard, B. E. (1973). Some effects of the hallucinogenic drug 2,5-dimethoxy-4-methyl amphetamine on the metabolism of biogenic amines in the rat brain. *Psychopharmacologia* 32, 33–49.
- Leonard, H. L., & Rapoport, J. L. (1987). Relief of obsessive-compulsive symptoms by LSD and psilocin. *Am J Psychiatry* 144, 1239–1240.
- Leslie, R. A., Moorman, J. M., Coulson, A., & Grahame-Smith, D. G. (1993). Serotonin<sub>2/1C</sub> receptor activation causes a localized expression of the immediate-early gene *c-fos* in rat brain: evidence for involvement of dorsal raphe nucleus projection fibres. *Neuroscience* 53, 457–463.
- Lewin, L. (1964). *Phantastica, Narcotic, and Stimulating Drugs. Their Use and Abuse*. London: Routledge and Kegan Paul.
- Leysen, J. E. (1985). Serotonin receptor binding sites. In A. R. Green (Ed.), *Neuropharmacology of Serotonin* (pp. 86–87). Oxford: Oxford University Press.
- Leysen, J. E., Niemegeers, C. J., Van Nueten, J. M., & Laduron, P. M. (1982). [<sup>3</sup>H]Ketanserin (R 41 468), a selective <sup>3</sup>H-ligand for serotonin<sub>2</sub> receptor binding sites. Binding properties, brain distribution, and functional role. *Mol Pharmacol* 21, 301–314.
- Leysen, J. E., Janssen, P. F., & Niemegeers, C. J. (1989). Rapid desensitization and down-regulation of 5-HT<sub>2</sub> receptors by DOM treatment. *Eur J Pharmacol* 163, 145–149.
- Lieberman, J. A., Mailman, R. B., Duncan, G., Sikich, L., Chakos, M., Nichols, D. E., & Kraus, J. E. (1998). Serotonergic basis of antipsychotic drug effects in schizophrenia. *Biol Psychiatry* 44, 1099–1117.
- Liu, C., Calogero, A., Ragona, G., Adamson, E., & Mercola, D. (1996). EGR-1, the reluctant suppression factor: EGR-1 is known to function in the regulation of growth, differentiation, and also has significant tumor suppressor activity and a mechanism involving the induction of TGF-beta1 is postulated to account for this suppressor activity. *Crit Rev Oncog* 7, 101–125.
- Liu, R., Jolas, T., & Aghajanian, G. (2000). Serotonin 5-HT(2) receptors



- activate local GABA inhibitory inputs to serotonergic neurons of the dorsal raphe nucleus. *Brain Res* 873, 34–45.
- Lucas, G., & Spampinato, U. (2000). Role of striatal serotonin<sub>2A</sub> and serotonin<sub>2C</sub> receptor subtypes in the control of in vivo dopamine outflow in the rat striatum. *J Neurochem* 74, 693–701.
- Lucki, I., Nobler, M. S., & Frazer, A. (1984). Differential actions of serotonin antagonists on two behavioral models of serotonin receptor activation in the rat. *J Pharmacol Exp Ther* 228, 133–139.
- Mackowiak, M., Chocyk, A., Fijal, K., Czyrak, A., & Wedzony, K. (1999). c-Fos proteins, induced by the serotonin receptor agonist DOI, are not expressed in 5-HT<sub>2A</sub> positive cortical neurons. *Brain Res Mol Brain Res* 71, 358–363.
- Mangini, M. (1998). Treatment of alcoholism using psychedelic drugs: a review of the program of research. *J Psychoactive Drugs* 30, 381–418.
- Manning, D. R. (2002). Measures of efficacy using G proteins as endpoints: differential engagement of G proteins through single receptors. *Mol Pharmacol* 62, 451–452.
- Marek, G. J., & Aghajanian, G. K. (1994). Excitation of interneurons in piriform cortex by 5-hydroxytryptamine: blockade by MDL 100,907, a highly selective 5-HT<sub>2A</sub> receptor antagonist. *Eur J Pharmacol* 259, 137–141.
- Marek, G. J., & Aghajanian, G. (1996a). Serotonergic amplification of apically-derived EPSPs in neocortical pyramidal cells via a persistent sodium current. *Soc Neurosci Abstr* 22, 525.9.
- Marek, G. J., & Aghajanian, G. K. (1996b). Alpha 1B-adrenoceptor-mediated excitation of piriform cortical interneurons. *Eur J Pharmacol* 305, 95–100.
- Marek, G. J., & Aghajanian, G. K. (1996c). LSD and the phenethylamine hallucinogen DOI are potent partial agonists at 5-HT<sub>2A</sub> receptors on interneurons in rat piriform cortex. *J Pharmacol Exp Ther* 278, 1373–1382.
- Marek, G. J., & Aghajanian, G. K. (1998a). 5-Hydroxytryptamine-induced excitatory postsynaptic currents in neocortical layer V pyramidal cells: suppression by mu-opiate receptor activation. *Neuroscience* 86, 485–497.
- Marek, G. J., & Aghajanian, G. K. (1998b). Indoleamine and the phenethylamine hallucinogens: mechanisms of psychotomimetic action. *Drug Alcohol Depend* 51, 189–198.
- Marek, G. J., & Aghajanian, G. K. (1999). 5-HT<sub>2A</sub> receptor or alpha1-adrenoceptor activation induces excitatory postsynaptic currents in layer V pyramidal cells of the medial prefrontal cortex. *Eur J Pharmacol* 367, 197–206.
- Marek, G. J., & Gewirtz, J. C. (1999). Serotonin<sub>2A</sub> receptor-induced EPSCs in layer V pyramidal cells of prefrontal cortex: block by lesions of the medial thalamus. *Soc Neurosci Abstr* 86, 438.
- Marek, G. J., Wright, R. A., Schoepp, D. D., Monn, J. A., & Aghajanian, G. K. (2000). Physiological antagonism between 5-hydroxytryptamine(2A) and group II metabotropic glutamate receptors in prefrontal cortex. *J Pharmacol Exp Ther* 292, 76–87.
- Marek, G. J., Wright, R. A., Gewirtz, J. C., & Schoepp, D. D. (2001). A major role for thalamocortical afferents in serotonergic hallucinogen receptor function in the rat neocortex. *Neuroscience* 105, 379–392.
- Marini-Bettolo, G. B., Chiavarelli, S., & Bovet, D. (1951). Synthetic sympatholytic substances of the ergotamine series: I. Nitrogen substituted derivatives of DL-1,2,3,4-tetrahydro-2-naphthylamine-containing amino and amido functional groups. *Gazz Chim Ital* 80, 281–298.
- Marona-Lewicka, D., & Nichols, D. E. (1995). Complex stimulus properties of LSD: a drug discrimination study with alpha 2-adrenoceptor agonists and antagonists. *Psychopharmacology (Berl)* 120, 384–391.
- Marona-Lewicka, D., & Nichols, D. E. (2002). Behavioral alterations in rats following long-term treatment with low doses of LSD. *5th IUPHAR Satellite Meeting on Serotonin* 114.
- Marona-Lewicka, D., Rhee, G. S., Sprague, J. E., & Nichols, D. E. (1996). Reinforcing effects of certain serotonin-releasing amphetamine derivatives. *Pharmacol Biochem Behav* 53, 99–105.
- Marona-Lewicka, D., Kurrasch-Orbaugh, D. M., Selken, J. R., Cumbay, M. G., Lisnicchia, J. G., & Nichols, D. E. (2002). Re-evaluation of lisuride pharmacology: 5-hydroxytryptamine<sub>1A</sub> receptor-mediated behavioral effects overlap its other properties in rats. *Psychopharmacology (Berl)* 164, 93–107.
- Martin, L. L., & Sanders-Bush, E. (1982). Comparison of the pharmacological characteristics of 5 HT<sub>1</sub> and 5 HT<sub>2</sub> binding sites with those of serotonin autoreceptors which modulate serotonin release. *Naunyn-Schmiedeberg's Arch Pharmacol* 321, 165–170.
- Martin-Ruiz, R., Puig, M. V., Celada, P., Shapiro, D. A., Roth, B. L., Mengod, G., & Artigas, F. (2001). Control of serotonergic function in medial prefrontal cortex by serotonin-2A receptors through a glutamate-dependent mechanism. *J Neurosci* 21, 9856–9866.
- Mazzola-Pomietto, P., Aulakh, C. S., Wozniak, K. M., Hill, J.L., & Murphy, D. L. (1995). Evidence that 1-(2,5-dimethoxy-4-iodophenyl)-2-amino-propane (DOI)-induced hyperthermia in rats is mediated by stimulation of 5-HT<sub>2A</sub> receptors. *Psychopharmacology (Berl)* 117, 193–199.
- McClue, S. J., Brazell, C., & Stahl, S. M. (1989). Hallucinogenic drugs are partial agonists of the human platelet shape change response: a physiological model of the 5-HT<sub>2</sub> receptor. *Biol Psychiatry* 26, 297–302.
- McCormick, D. A., & Bal, T. (1997). Sleep and arousal: thalamocortical mechanisms. *Annu Rev Neurosci* 20, 185–215.
- McCormick, D. A., & Feeser, H. R. (1990). Functional implications of burst firing and single spike activity in lateral geniculate relay neurons. *Neuroscience* 39, 103–113.
- McGlothlin, W. H., & Arnold, D. O. (1971). LSD revisited. A ten-year follow-up of medical LSD use. *Arch Gen Psychiatry* 24, 35–49.
- McGrew, L., Chang, M. S., & Sanders-Bush, E. (2002). Phospholipase D activation by endogenous 5-hydroxytryptamine 2C receptors is mediated by Galpha13 and pertussis toxin-insensitive Gbetagamma subunits. *Mol Pharmacol* 62, 1339–1343.
- McKenna, D. J., Nazarali, A. J., Himeno, A., & Saavedra, J. M. (1989a). Chronic treatment with (±)DOI, a psychotomimetic 5-HT<sub>2</sub> agonist, downregulates 5-HT<sub>2</sub> receptors in rat brain. *Neuropsychopharmacology* 2, 81–87.
- McKenna, D. J., Nazarali, A. J., Hoffman, A. J., Nichols, D. E., Mathis, C. A., & Saavedra, J.M. (1989b). Common receptors for hallucinogens in rat brain: a comparative autoradiographic study using [<sup>125</sup>I]LSD and [<sup>125</sup>I]DOI, a new psychotomimetic radioligand. *Brain Res* 476, 45–56.
- McKenna, D. J., & Saavedra, J. M. (1987). Autoradiography of LSD and 2,5-dimethoxyphenylisopropylamine psychotomimetics demonstrates regional, specific cross-displacement in the rat brain. *Eur J Pharmacol* 142, 313–315.
- McKenna, D. J., & Towers, G. H. (1984). Biochemistry and pharmacology of tryptamines and beta-carbolines. A minireview. *J Psychoactive Drugs* 16, 347–358.
- McKenna, D. J., Towers, G. H., & Abbott, F. (1984). Monoamine oxidase inhibitors in South American hallucinogenic plants: tryptamine and beta-carboline constituents of ayahuasca. *J Ethnopharmacol* 10, 195–223.
- McKenna, D. J., Repke, D. B., Lo, L., & Peroutka, S. J. (1990). Differential interactions of indolealkylamines with 5-hydroxytryptamine receptor subtypes. *Neuropharmacology* 29, 193–198.
- Meehan, S. M., & Schechter, M. D. (1994). Conditioned place preference/aversion to fenfluramine in Fawn Hooded and Sprague-Dawley rats. *Prog Neuropsychopharmacol Biol Psychiatry* 18, 575–584.
- Meehan, S. M., & Schechter, M. D. (1998). LSD produces conditioned place preference in male but not female Fawn Hooded rats. *Pharmacol Biochem Behav* 59, 105–108.
- Meert, T. F., De Haes, P. L. A. J., & Vermote, P. C. M. (1990). The discriminative stimulus properties of LSD: serotonergic and catecholaminergic interactions. *Psychopharmacology (Berl)* 101, S71(271).
- Meert, T. F., de Haes, P., & Janssen, P. A. (1989). Risperidone (R 64 766), a potent and complete LSD antagonist in drug discrimination by rats. *Psychopharmacology (Berl)* 97, 206–212.
- Meibach, R. C., Maayani, S., & Green, J. P. (1980). Characterization and radioautography of [<sup>3</sup>H]LSD binding by rat brain slices in vitro: the effect of 5-hydroxytryptamine. *Eur J Pharmacol* 67, 371–382.
- Meltzer, H. Y. (1991). The mechanism of action of novel antipsychotic

- drugs. In J. M. Kane (Ed.), *New Developments in the Pharmacologic Treatment of Schizophrenia* (pp. 71–95). Washington, DC: NIMH Public Health Service.
- Meltzer, H. Y. (1999). The role of serotonin in antipsychotic drug action. *Neuropsychopharmacology* 21, 106S–115S.
- Meltzer, H. Y., Fessler, R. G., Simonovic, M., Doherty, J., & Fang, V. S. (1977). Lysergic acid diethylamide: evidence for stimulation of pituitary dopamine receptors. *Psychopharmacology (Berl)* 54, 39–44.
- Meltzer, H. Y., Wiita, B., Tricou, B. J., Simonovic, M., Fang, V. S., & Manov, G. (1982). Effects of serotonin precursors and serotonin agonists on plasma hormone levels. In B. T. Ho, J. D. Schoolar, & E. Usdin (Eds.), *Serotonin in Biological Psychiatry* (pp. 71–95). New York: Raven Press.
- Meltzer, H. Y., Matsubara, S., & Lee, J.C. (1989). Classification of typical and atypical antipsychotic drugs on the basis of dopamine D-1, D-2 and serotonin<sub>2</sub> pK<sub>i</sub> values. *J Pharmacol Exp Ther* 251, 238–246.
- Mengod, G., Pompeiano, M., Martinez-Mir, M. I., & Palacios, J. M. (1990). Localization of the mRNA for the 5-HT<sub>2</sub> receptor by in situ hybridization histochemistry. Correlation with the distribution of receptor sites. *Brain Res* 524, 139–143.
- Miner, L. H., Schroeter, S., Blakely, R. D., & Sesack, S. R. (2000). Ultrastructural localization of the serotonin transporter in superficial and deep layers of the rat prelimbic prefrontal cortex and its spatial relationship to dopamine terminals. *J Comp Neurol* 427, 220–234.
- Miner, L. A., Backstrom, J. R., Sanders-Bush, E., & Sesack, S. R. (2003). Ultrastructural localization of serotonin<sub>2A</sub> receptors in the middle layers of the rat prelimbic prefrontal cortex. *Neuroscience* 116, 107–117.
- Mitchell, R., McCulloch, D., Lutz, E., Johnson, M., MacKenzie, C., Fennell, M., Fink, G., Zhou, W., & Sealfon, S. C. (1998). Rhodopsin-family receptors associate with small G proteins to activate phospholipase D. *Nature* 392, 411–414.
- Monte, A. P., Waldman, S. R., Marona-Lewicka, D., Waincott, D. B., Nelson, D. L., Sanders-Bush, E., & Nichols, D. E. (1997). Dihydrobenzofuran analogues of hallucinogens: 4. Mescaline derivatives. *J Med Chem* 40, 2997–3008.
- Monte, A. P., Marona-Lewicka, D., Lewis, M. M., Mailman, R. B., Waincott, D. B., Nelson, D. L., & Nichols, D. E. (1998). Substituted naphthofurans as hallucinogenic phenethylamine-ergoline hybrid molecules with unexpected muscarinic antagonist activity. *J Med Chem* 41, 2134–2145.
- Moore, R. Y., Halaris, A. E., & Jones, B. E. (1978). Serotonin neurons of the midbrain raphe: ascending projections. *J Comp Neurol* 180, 417–438.
- Moorman, J. M., & Leslie, R. A. (1996). *p*-Chloroamphetamine induces *c-fos* in rat brain: a study of serotonin<sub>2A/2C</sub> receptor function. *Neuroscience* 72, 129–139.
- Moreno, F. A., & Delgado, P. L. (1997). Hallucinogen-induced relief of obsessions and compulsions. *Am J Psychiatry* 154, 1037–1038.
- Mottola, D. M., Kilts, J. D., Lewis, M. M., Connery, H. S., Walker, Q. D., Jones, S. R., Booth, R. G., Hyslop, D. K., Piercey, M., Wightman, R. M., Lawler, C. P., Nichols, D. E., & Mailman, R. B. (2002). Functional selectivity of dopamine receptor agonists: I. Selective activation of postsynaptic dopamine D<sub>2</sub> receptors linked to adenylate cyclase. *J Pharmacol Exp Ther* 301, 1166–1178.
- Muller, B. M., Kistner, U., Kindler, S., Chung, W. J., Kuhlendahl, S., Fenster, S. D., Lau, L. F., Veh, R. W., Huganir, R. L., Gundelfinger, E. D., & Garner, C. C. (1996). SAP102, a novel postsynaptic protein that interacts with NMDA receptor complexes in vivo. *Neuron* 17, 255–265.
- Nakada, M. T., Wieczorek, C. M., & Rainbow, T. C. (1984). Localization and characterization by quantitative autoradiography of [<sup>125</sup>I]LSD binding sites in rat brain. *Neurosci Lett* 49, 13–18.
- Nanry, K. P., & Tilson, H. A. (1989). The role of 5HT<sub>1A</sub> receptors in the modulation of the acoustic startle reflex in rats. *Psychopharmacology (Berl)* 97, 507–513.
- Nash, J. F., Roth, B. L., Brodwin, J. D., Nichols, D. E., & Gudelsky, G. A. (1994). Effect of the *R*(–) and *S*(+) isomers of MDA and MDMA on phosphatidyl inositol turnover in cultured cells expressing 5-HT<sub>2A</sub> or 5-HT<sub>2C</sub> receptors. *Neurosci Lett* 177, 111–115.
- Nelson, D. L., Lucaites, V. L., Audia, J. E., Nissen, J. S., & Waincott, D. B. (1993). Species differences in the pharmacology of the 5-hydroxytryptamine<sub>2</sub> receptor: structurally specific differentiation by ergolines and tryptamines. *J Pharmacol Exp Ther* 265, 1272–1279.
- Nelson, D. L., Lucaites, V. L., Waincott, D. B., & Glennon, R. A. (1999). Comparisons of hallucinogenic phenylisopropylamine binding affinities at cloned human 5-HT<sub>2A</sub>, 5-HT<sub>2B</sub> and 5-HT<sub>2C</sub> receptors. *Naunyn-Schmiedeberg's Arch Pharmacol* 359, 1–6.
- Nichols, D. E. (1976). Structural correlation between apomorphine and LSD: involvement of dopamine as well as serotonin in the actions of hallucinogens. *J Theor Biol* 59, 167–177.
- Nichols, D. E. (1981). Structure-activity relationships of phenethylamine hallucinogens. *J Pharm Sci* 70, 839–849.
- Nichols, D. E. (1986). Hallucinogens. In M. Verderame (Ed.), *Handbook of CNS Agents and Local Anesthetics* (pp. 303–325). Boca Raton: CRC Press.
- Nichols, D. E. (1994). Medicinal chemistry and structure-activity relationships. In A. K. Cho, & D. S. Segal (Eds.), *Amphetamine and Its Analogs* (pp. 3–41). New York: Academic Press.
- Nichols, D. E. (1997). Role of serotonergic neurons and 5-HT receptors in the action of hallucinogens. In H. G. Baumgarten, & M. Gothert (Eds.), *Serotonergic Neurons and 5-HT Receptors in the CNS* (pp. 563–585). Berlin: Springer-Verlag.
- Nichols, D. E., & Oberlender, R. (1989). Structure-activity relationships of MDMA-like substances. *NIDA Res Monogr* 94, 1–29.
- Nichols, D. E., & Oberlender, R. (1990). Structure-activity relationships of MDMA and related compounds: a new class of psychoactive agents? In S. J. Peroutka (Ed.), *Ecstasy: The Clinical, Pharmacological and Neurotoxicological Effects of The Drug MDMA* (pp. 105–131). Boston: Kluwer Academic Publishing.
- Nichols, C. D., & Sanders-Bush, E. (2002). A single dose of lysergic acid diethylamide influences gene expression patterns within the mammalian brain. *Neuropsychopharmacology* 26, 634–642.
- Nichols, D. E., Ilhan, M., & Long, J. P. (1975). Comparison of cardiovascular, hyperthermic, and toxic effects of *para*-methoxyamphetamine (PMA) and 3, 4-methylenedioxyamphetamine (MDA). *Arch Int Pharmacodyn Ther* 214, 133–140.
- Nichols, D. E., Shulgin, A. T., & Dyer, D. C. (1977). Directional lipophilic character in a series of psychotomimetic phenethylamine derivatives. *Life Sci* 21, 569–575.
- Nichols, D. E., Jadhav, K. P., Oberlender, R. A., Zabik, J. E., Bossart, J. F., Hamada, A., & Miller, D. D. (1984a). Synthesis and evaluation of substituted 2-phenylcyclobutylamines as analogues of hallucinogenic phenethylamines: lack of LSD-like biological activity. *J Med Chem* 27, 1108–1111.
- Nichols, D. E., Schooler, D., Yeung, M. C., Oberlender, R. A., & Zabik, J. E. (1984b). Unreliability of the rat stomach fundus as a predictor of hallucinogenic activity in substituted phenethylamines. *Life Sci* 35, 1343–1348.
- Nichols, D. E., Hoffman, A. J., Oberlender, R. A., & Riggs, R. M. (1986). Synthesis and evaluation of 2,3-dihydrobenzofuran analogues of the hallucinogen 1-(2,5-dimethoxy-4-methylphenyl)-2-aminopropane: drug discrimination studies in rats. *J Med Chem* 29, 302–304.
- Nichols, D. E., Oberlender, R., & McKenna, D. J. (1991). Stereochemical aspects of hallucinogenesis. In R. R. Watson (Ed.), *Biochemistry and Physiology of Substance Abuse* (pp. 1–39). Boca Raton: CRC Press.
- Nichols, D. E., Snyder, S. E., Oberlender, R., Johnson, M. P., & Huang, X. M. (1991). 2,3-Dihydrobenzofuran analogues of hallucinogenic phenethylamines. *J Med Chem* 34, 276–281.
- Nichols, D. E., Frescas, S., Marona-Lewicka, D., Huang, X., Roth, B. L., Gudelsky, G. A., & Nash, J. F. (1994). 1-(2,5-Dimethoxy-4-(trifluoromethyl)phenyl)-2-aminopropane: a potent serotonin 5-HT<sub>2A/2C</sub> agonist. *J Med Chem* 37, 4346–4351.
- Nichols, D. E., Frescas, S., Marona-Lewicka, D., & Kurrasch-Orbaugh, D. M. (2002). Lysergamides of isomeric 2,4-dimethylazetidines map the binding orientation of the diethylamide moiety in the potent

- hallucinogenic agent *N,N*-diethyllysergamide (LSD). *J Med Chem* 45, 4344–4349.
- Nichols, C. D., Garcia, E. E., & Sanders-Bush, E. (2003). Dynamic changes in prefrontal cortex gene expression following lysergic acid diethylamide administration. *Brain Res Mol Brain Res* 111, 182–188.
- NIDA, E. (2002). Monitoring the Future Study. (<http://www.nida.nih.gov>).
- Nieforth, K. A. (1971). Psychotomimetic phenethylamines. *J Pharm Sci* 60, 655–665.
- Nielsen, E. B. (1985). Discriminative stimulus properties of lysergic acid diethylamide in the monkey. *J Pharmacol Exp Ther* 234, 244–249.
- Niethammer, M., Kim, E., & Sheng, M. (1996). Interaction between the C terminus of NMDA receptor subunits and multiple members of the PSD-95 family of membrane-associated guanylate kinases. *J Neurosci* 16, 2157–2163.
- Nocjar, C., Roth, B. L., & Pehek, E. A. (2002). Localization of 5-HT(2A) receptors on dopamine cells in subnuclei of the midbrain A10 cell group. *Neuroscience* 111, 163–176.
- Norman, A. B., Nash, D. R., & Sanberg, P. R. (1989). [<sup>3</sup>H]Lysergic acid diethylamide (LSD): differential agonist and antagonist binding properties at 5-HT receptor subtypes in rat brain. *Neurochem Int* 14, 497–504.
- O'Brien, C. P. (2001). Drug addiction and drug abuse. In J. G. Hardman, L. E. Limbird, P. B. Molinoff, R. W. Ruddon, & A. G. Gilman (Eds.), *Goodman and Gilman's the Pharmacological Basis of Therapeutics* (pp. 574–639). New York: McGraw-Hill.
- O'Leary, G., Nargiso, J., & Weiss, R. D. (2001). 3,4-Methylenedioxymethamphetamine (MDMA): a review. *Curr Psychiatry Rep* 3, 477–483.
- Oepen, G., Fuenfgeld, M., Harrington, A., Hermle, L., & Botsch, H. (1989). Right hemisphere involvement in mescaline-induced psychosis. *Psychiatry Res* 29, 335–336.
- Ogren, S. O., & Fuxe, K. (1989). Intraventricular injections of galanin counteract development of head twitches induced by the 5-HT-2 agonist 1-(2,5-dimethoxyphenyl-4-bromo)-2-aminopropane. *Acta Physiol Scand* 136, 297–298.
- Osmond, H. (1957). A review of the clinical effects of psychotomimetic agents. *Ann NY Acad Sci* 66, 418–434.
- Osmond, H., & Smythies, J. (1952). Schizophrenia: a new approach. *J Ment Sci* 98, 309–315.
- Ott, J. (2001). Pharmepena-psychonautics: human intranasal, sublingual and oral pharmacology of 5-methoxy-*N,N*-dimethyl-tryptamine. *J Psychoactive Drugs* 33, 403–407.
- Ott, J., & Bigwood, J. (1978). *Teonanacatl Hallucinogenic Mushrooms of North America*. Seattle, WA: Madrona.
- Owens, M. J., Knight, D. L., Ritchie, J. C., & Nemeroff, C. B. (1991). The 5-hydroxytryptamine<sub>2</sub> agonist, (±)-1-(2,5-dimethoxy-4-bromophenyl)-2-aminopropane stimulates the hypothalamic-pituitary-adrenal (HPA) axis: I. Acute effects on HPA axis activity and corticotropin-releasing factor-containing neurons in the rat brain. *J Pharmacol Exp Ther* 256, 787–794.
- Owens, M. J., Knight, D. L., Ritchie, J. C., & Nemeroff, C. B. (1991). The 5-hydroxytryptamine<sub>2</sub> agonist, (±)-1-(2,5-dimethoxy-4-bromophenyl)-2-aminopropane stimulates the hypothalamic-pituitary-adrenal (HPA) axis: II. Biochemical and physiological evidence for the development of tolerance after chronic administration. *J Pharmacol Exp Ther* 256, 795–800.
- Padich, R. A., McCloskey, T. C., & Kehne, J. H. (1996). 5-HT modulation of auditory and visual sensorimotor gating: II. Effects of the 5-HT<sub>2A</sub> antagonist MDL 100,907 on disruption of sound and light prepulse inhibition produced by 5-HT agonists in Wistar rats. *Psychopharmacology (Berl)* 124, 107–116.
- Pahnke, W. N. (1963). *Drugs and Mysticism. An Analysis of the Relationship Between Psychedelic Drugs and the Mystical Consciousness*. Ph.D. dissertation, Harvard University, Cambridge, UK.
- Pahnke, W. N., Kurland, A. A., Goodman, L.E., & Richards, W. A. (1969). LSD-assisted psychotherapy with terminal cancer patients. *Curr Psychiatr Ther* 9, 144–152.
- Pahnke, W. N., Kurland, A. A., Unger, S., Savage, C., & Grof, S. (1970). The experimental use of psychedelic (LSD) psychotherapy. *JAMA* 212, 1856–1863.
- Palacios, J. M., Probst, A., & Cortes, R. (1983). The distribution of serotonin receptors in the human brain: high density of [<sup>3</sup>H]LSD binding sites in the raphe nuclei of the brainstem. *Brain Res* 274, 150–155.
- Parker, L. A. (1996). LSD produces place preference and flavor avoidance but does not produce flavor aversion in rats. *Behav Neurosci* 110, 503–508.
- Parker, M. A., Marona-Lewicka, D., Lucaites, V. L., Nelson, D. L., & Nichols, D. E. (1998). A novel (benzodifuranyl)aminoalkane with extremely potent activity at the 5-HT<sub>2A</sub> receptor. *J Med Chem* 41, 5148–5149.
- Pazos, A., & Palacios, J. M. (1985). Quantitative autoradiographic mapping of serotonin receptors in the rat brain: I. Serotonin-1 receptors. *Brain Res* 346, 205–230.
- Pazos, A., Cortes, R., & Palacios, J. M. (1985). Quantitative autoradiographic mapping of serotonin receptors in the rat brain: II. Serotonin-2 receptors. *Brain Res* 346, 231–249.
- Pazos, A., Probst, A., & Palacios, J. M. (1987). Serotonin receptors in the human brain: IV. Autoradiographic mapping of serotonin-2 receptors. *Neuroscience* 21, 123–139.
- Pehek, E. A., McFarlane, H. G., Maguschak, K., Price, B., & Pluto, C. P. (2001). M100,907, a selective 5-HT(2A) antagonist, attenuates dopamine release in the rat medial prefrontal cortex. *Brain Res* 888, 51–59.
- Pei, Q., Lewis, L., Sprakes, M. E., Jones, E. J., Grahame-Smith, D. G., & Zetterstrom, T. S. (2000). Serotonergic regulation of mRNA expression of Arc, an immediate early gene selectively localized at neuronal dendrites. *Neuropharmacology* 39, 463–470.
- Pessia, M., Jiang, Z. G., North, R. A., & Johnson, S. W. (1994). Actions of 5-hydroxytryptamine on ventral tegmental area neurons of the rat in vitro. *Brain Res* 654, 324–330.
- Pierce, P. A., & Peroutka, S. J. (1988). Antagonism of 5-hydroxytryptamine<sub>2</sub> receptor-mediated phosphatidylinositol turnover by D-lysergic acid diethylamide. *J Pharmacol Exp Ther* 247, 918–925.
- Pierce, P. A., & Peroutka, S. J. (1989). Hallucinogenic drug interactions with neurotransmitter receptor binding sites in human cortex. *Psychopharmacology (Berl)* 97, 118–122.
- Pierce, P. A., & Peroutka, S. J. (1990). Antagonist properties of D-LSD at 5-hydroxytryptamine<sub>2</sub> receptors. *Neuropsychopharmacology* 3, 503–508.
- Pieri, L., Pieri, M., & Haefely, W. (1974). LSD as an agonist of dopamine receptors in the striatum. *Nature* 252, 586–588.
- Poling, J. S., Karanian, J. W., Salem Jr, N., & Vicini, S. (1995). Time- and voltage-dependent block of delayed rectifier potassium channels by docosahexaenoic acid. *Mol Pharmacol* 47, 381–390.
- Poling, J. S., Rogawski, M. A., Salem Jr, N., & Vicini, S. (1996). Anandamide, an endogenous cannabinoid, inhibits Shaker-related voltage-gated K<sup>+</sup> channels. *Neuropharmacology* 35, 983–991.
- Pompeiano, M., Palacios, J. M., & Mengod, G. (1994). Distribution of the serotonin 5-HT<sub>2</sub> receptor family mRNAs: comparison between 5-HT<sub>2A</sub> and 5-HT<sub>2C</sub> receptors. *Brain Res Mol Brain Res* 23, 163–178.
- Prada, M. D., Saner, A., Burkark, W. P., Bartholini, G., & Pletscher, A. (1975). Lysergic acid diethylamide: evidence for stimulation of cerebral dopamine receptors. *Brain Res* 94, 67–73.
- Prange, O., & Murphy, T. H. (2001). Modular transport of postsynaptic density-95 clusters and association with stable spine precursors during early development of cortical neurons. *J Neurosci* 21, 9325–9333.
- Qu, Y., Chang, L., Klaff, J., Balbo, A., & Rapoport, S. I. (2003). Imaging brain phospholipase A<sub>2</sub> activation in awake rats in response to the 5-HT<sub>2A/2C</sub> agonist (±)2,5-dimethoxy-4-iodophenyl-2-aminopropane (DOI). *Neuropsychopharmacology* 28, 244–252.
- Rabin, R. A., Regina, M., Doat, M., & Winter, J. C. (2002). 5-HT(2A) receptor-stimulated phosphoinositide hydrolysis in the stimulus effects of hallucinogens. *Pharmacol Biochem Behav* 72, 29–37.
- Randic, M., & Padjen, A. (1971). Effect of *N,N*-dimethyltryptamine and D-lysergic acid diethylamide on the release of 5-hydroxyindoles in rat forebrain. *Nature* 230, 532–533.
- Rasmussen, K., & Aghajanian, G. K. (1986). Effect of hallucinogens on



- spontaneous and sensory-evoked locus coeruleus unit activity in the rat: reversal by selective 5-HT<sub>2</sub> antagonists. *Brain Res* 385, 395–400.
- Rasmussen, K., Glennon, R. A., & Aghajanian, G. K. (1986). Phenethylamine hallucinogens in the locus coeruleus: potency of action correlates with rank order of 5-HT<sub>2</sub> binding affinity. *Eur J Pharmacol* 132, 79–82.
- Regier, D. A., Boyd, J. H., Burke Jr., J. D., Rae, D. S., Myers, J. K., Kramer, M., Robins, L. N., George, L. K., Karno, M., & Locke, B. Z. (1988). One-month prevalence of mental disorders in the United States. Based on five epidemiologic catchment area sites. *Arch Gen Psychiatry* 45, 977–986.
- Resnick, O., Krus, D. M., & Raskin, M. (1965). Accentuation of the psychological effects of LSD-25 in normal subjects treated with reserpine. *Life Sci* 4, 1433–1437.
- Reynolds, P. C., & Jindrich, E. J. (1985). A mescaline associated fatality. *J Anal Toxicol* 9, 183–184.
- Riba, J., Anderer, P., Morte, A., Urbano, G., Jane, F., Saletu, B., & Barbanoj, M. J. (2002). Topographic pharmaco-EEG mapping of the effects of the South American psychoactive beverage ayahuasca in healthy volunteers. *Br J Clin Pharmacol* 53, 613–628.
- Riba, J., Valle, M., Urbano, G., Yritia, M., Morte, A., & Barbanoj, M. J. (2003). Human pharmacology of ayahuasca: subjective and cardiovascular effects, monoamine metabolite excretion, and pharmacokinetics. *J Pharmacol Exp Ther* 306, 73–83.
- Robertson, D. N., Johnson, M. S., Moggach, L. O., Holland, P. J., Lutz, E. M., & Mitchell, R. (2003). Selective interaction of ARF1 with the carboxy-terminal tail domain of the 5-HT<sub>2A</sub> receptor. *Mol Pharmacol* 64, 1239–1250.
- Rogawski, M. A., & Aghajanian, G. K. (1979). Response of central monoaminergic neurons to lisuride: comparison with LSD. *Life Sci* 24, 1289–1297.
- Romano, A. G., & Harvey, J. A. (1994). MDMA enhances associative and nonassociative learning in the rabbit. *Pharmacol Biochem Behav* 47, 289–293.
- Romano, A. G., Bormann, N. M., & Harvey, J. A. (1991). A unique enhancement of associative learning produced by methylenedioxyamphetamine. *Behav Pharmacol* 2, 225–231.
- Rosecrans, J. A., Lovell, R. A., & Freedman, D. X. (1967). Effects of lysergic acid diethylamide on the metabolism of brain 5-hydroxytryptamine. *Biochem Pharmacol* 16, 2011–2021.
- Roth, B. L., Nakaki, T., Chuang, D. M., & Costa, E. (1984). Aortic recognition sites for serotonin (5HT) are coupled to phospholipase C and modulate phosphatidylinositol turnover. *Neuropharmacology* 23, 1223–1225.
- Roth, B. L., McLean, S., Zhu, X. Z., & Chuang, D. M. (1987). Characterization of two [<sup>3</sup>H]ketanserin recognition sites in rat striatum. *J Neurochem* 49, 1833–1838.
- Roth, B. L., Palvimaki, E. P., Berry, S., Khan, N., Sachs, N., Uler, A., & Choudhary, M. S. (1995). 5-Hydroxytryptamine<sub>2A</sub> (5-HT<sub>2A</sub>) receptor desensitization can occur without down-regulation. *J Pharmacol Exp Ther* 275, 1638–1646.
- Roth, B. L., Choudhary, M. S., Khan, N., & Uler, A. Z. (1997a). High-affinity agonist binding is not sufficient for agonist efficacy at 5-hydroxytryptamine<sub>2A</sub> receptors: evidence in favor of a modified ternary complex model. *J Pharmacol Exp Ther* 280, 576–583.
- Roth, B. L., Shoham, M., Choudhary, M. S., & Khan, N. (1997b). Identification of conserved aromatic residues essential for agonist binding and second messenger production at 5-hydroxytryptamine<sub>2A</sub> receptors. *Mol Pharmacol* 52, 259–266.
- Roth, B. L., Berry, S. A., Kroeze, W. K., Willins, D. L., & Kristiansen, K. (1998). Serotonin 5-HT<sub>2A</sub> receptors: molecular biology and mechanisms of regulation. *Crit Rev Neurobiol* 12, 319–338.
- Rothlin, E. (1957). Lysergic acid diethylamide and related substances. *Ann NY Acad Sci* 66, 668–676.
- Ruck, C. A., Bigwood, J., Staples, D., Ott, J., & Wasson, R. G. (1979). Entheogens. *J Psychedelic Drugs* 11, 145–146.
- Sadzot, B., Baraban, J. M., Glennon, R. A., Lyon, R. A., Leonhardt, S., Jan, C. R., & Titeler, M. (1989). Hallucinogenic drug interactions at human brain 5-HT<sub>2</sub> receptors: implications for treating LSD-induced hallucinogenesis. *Psychopharmacology (Berl)* 98, 495–499.
- Sams-Dodd, F. (1999). Phencyclidine in the social interaction test: an animal model of schizophrenia with face and predictive validity. *Rev Neurosci* 10, 59–90.
- Sanchez-Vives, M. V., & McCormick, D. A. (2000). Cellular and network mechanisms of rhythmic recurrent activity in neocortex. *Nat Neurosci* 3, 1027–1034.
- Sanders-Bush, E. (1994). Neurochemical evidence that hallucinogenic drugs are 5-HT<sub>1C</sub> receptor agonists: what next? *NIDA Res Monogr* 146, 203–213.
- Sanders-Bush, E., & Breeding, M. (1991). Choroid plexus epithelial cells in primary culture: a model of 5HT<sub>1C</sub> receptor activation by hallucinogenic drugs. *Psychopharmacology (Berl)* 105, 340–346.
- Sanders-Bush, E., Burris, K. D., & Knoth, K. (1988). Lysergic acid diethylamide and 2,5-dimethoxy-4-methylamphetamine are partial agonists at serotonin receptors linked to phosphoinositide hydrolysis. *J Pharmacol Exp Ther* 246, 924–928.
- Savage, C., Jackson, D., & Terrill, J. (1962). LSD, transcendence, and the new beginning. *J Nerv Ment Dis* 135, 425–439.
- Schatz, H., & Mendelblatt, F. (1973). Serotonin retinopathy from sun-gazing under the influence of LSD. *Br J Ophthalmol* 57, 270–273.
- Schmidt, C. J., Fadayel, G. M., Sullivan, C. K., & Taylor, V. L. (1992). 5-HT<sub>2</sub> HT<sub>2</sub> receptors exert a state-dependent regulation of dopaminergic function: studies with MDL 100,907 and the amphetamine analogue, 3,4-methylenedioxyamphetamine. *Eur J Pharmacol* 223, 65–74.
- Schreiber, R., Brocco, M., & Millan, M. J. (1994). Blockade of the discriminative stimulus effects of DOI by MDL 100,907 and the “atypical” antipsychotics, clozapine and risperidone. *Eur J Pharmacol* 264, 99–102.
- Schreiber, R., Brocco, M., Audinot, V., Gobert, A., Veiga, S., & Millan, M. J. (1995). (1-(2,5-Dimethoxy-4-iodophenyl)-2-aminopropane)-induced head-twitches in the rat are mediated by 5-hydroxytryptamine (5-HT) 2A receptors: modulation by novel 5-HT<sub>2A/2C</sub> antagonists, D<sub>1</sub> antagonists and 5-HT<sub>1A</sub> agonists. *J Pharmacol Exp Ther* 273, 101–112.
- Schultes, R. E., & Hofmann, A. (1979). Plants of the Gods. *Origins of Hallucinogenic Use*. New York: Alfred van der Marck Editions.
- Scruggs, J. L., Patel, S., Bubser, M., & Deutch, A. Y. (2000). DOI-induced activation of the cortex: dependence on 5-HT<sub>2A</sub> heteroreceptors on thalamocortical glutamatergic neurons. *J Neurosci* 20, 8846–8852.
- Scruggs, J. L., Schmidt, D., & Deutch, A. Y. (2003). The hallucinogen 1-[2,5-dimethoxy-4-iodophenyl]-2-aminopropane (DOI) increases cortical extracellular glutamate levels in rats. *Neurosci Lett* 346, 137–140.
- Sealfon, S. C., Chi, L., Ebersole, B. J., Rodic, V., Zhang, D., Ballesteros, J. A., & Weinstein, H. (1995). Related contribution of specific helix 2 and 7 residues to conformational activation of the serotonin 5-HT<sub>2A</sub> receptor. *J Biol Chem* 270, 16683–16688.
- Sebben, M., Ansanay, H., Bockaert, J., & Dumuis, A. (1994). 5-HT<sub>6</sub> receptors positively coupled to adenylyl cyclase in striatal neurones in culture. *NeuroReport* 5, 2553–2557.
- Seguela, P., Watkins, K. C., & Descarries, L. (1989). Ultrastructural relationships of serotonin axon terminals in the cerebral cortex of the adult rat. *J Comp Neurol* 289, 129–142.
- Shapiro, D. A., Kristiansen, K., Kroeze, W. K., & Roth, B. L. (2000). Differential modes of agonist binding to 5-hydroxytryptamine(2A) serotonin receptors revealed by mutation and molecular modeling of conserved residues in transmembrane region 5. *Mol Pharmacol* 58, 877–886.
- Shapiro, D. A., Kristiansen, K., Weiner, D. M., Kroeze, W. K., & Roth, B. L. (2002). Evidence for a model of agonist-induced activation of 5-hydroxytryptamine 2A serotonin receptors that involves the disruption of a strong ionic interaction between helices 3 and 6. *J Biol Chem* 277, 11441–11449.
- Shaw, E., & Woolley, D. W. (1956). Some serotonin-like activities of lysergic acid diethylamide. *Science* 124, 121.
- Sheldon, P. W., & Aghajanian, G. K. (1990). Serotonin (5-HT) induces



- IPSPs in pyramidal layer cells of rat piriform cortex: evidence for the involvement of a 5-HT<sub>2</sub>-activated interneuron. *Brain Res* 506, 62–69.
- Sheng, M. (2001). Molecular organization of the postsynaptic specialization. *Proc Natl Acad Sci USA* 98, 7058–7061.
- Sherman, S. M., & Guillery, R. W. (1996). Functional organization of thalamocortical relays. *J Neurophysiol* 76, 1367–1395.
- Shih, J. C., Chen, K., & Gallaher, T. K. (1994). Structure and function of serotonin 5-HT<sub>2</sub> receptors. *NIDA Res Monogr* 146, 284–297.
- Shulgin, A. T. (1973). Mescaline: the chemistry and pharmacology of its analogs. *Lloydia* 36, 46–58.
- Shulgin, A. T. (1978). Psychotomimetic drugs: structure-activity relationships. In: L. L. Iversen, S. D. Iversen, & S. H. Snyder (Eds.), *Handbook of Psychopharmacology* (pp. 243–333). New York: Plenum.
- Shulgin, A. T. (1980). Profiles of psychedelic drugs. Psilocybin. *J Psychedelic Drugs* 12, 79.
- Shulgin, A. T. (1981). Chemistry of psychotomimetics. In F. Hoffmeister, & G. Stille (Eds.), *Handbook of Experimental Pharmacology* (pp. 3–29). Heidelberg: Springer-Verlag.
- Shulgin, A., & Shulgin, A. (1991). *PIHKAL a Chemical Love Story*. Berkeley, CA: Transform Press.
- Shulgin, A. T., & Shulgin, A. (1997). *TIHKAL. The Continuation*. Berkeley, CA: Transform Press.
- Siegel, S., & Freedman, D. X. (1988). Effects of LSD-25 on classical trace conditioning. *Pharmacol Biochem Behav* 30, 427–431.
- Siva Sankar, D.V. (1975). *LSD: A Total Study*. Westbury, NY: PJD Publications.
- Smith, R. L., Canton, H., Barrett, R. J., & Sanders-Bush, E. (1998). Agonist properties of *N,N*-dimethyltryptamine at serotonin 5-HT<sub>2A</sub> and 5-HT<sub>2C</sub> receptors. *Pharmacol Biochem Behav* 61, 323–330.
- Smith, R. L., Barrett, R. J., & Sanders-Bush, E. (1999). Mechanism of tolerance development to 2,5-dimethoxy-4-iodoamphetamine in rats: down-regulation of the 5-HT<sub>2A</sub>, but not 5-HT<sub>2C</sub>, receptor. *Psychopharmacology (Berl)* 144, 248–254.
- Smythies, J. (1997). The functional neuroanatomy of awareness: with a focus on the role of various anatomical systems in the control of intermodal attention. *Conscious Cogn* 6, 455–481.
- Smythies, J. R., Sykes, E. A., & Lord, C. P. (1966). Structure-activity relationship studies on mescaline: II. Tolerance and cross-tolerance between mescaline and its analogues in the rat. *Psychopharmacologia* 9, 434–446.
- Sotelo, C., Cholley, B., El Mestikawy, S., Gozlan, H., & Hamon, M. (1990). Direct immunohistochemical evidence of the existence of 5-HT<sub>1A</sub> autoreceptors on serotonergic neurons in the midbrain raphe nuclei. *Eur J Neurosci* 2, 1144–1154.
- Spano, P. F., Kumakura, K., Tonon, G. C., Govoni, S., & Trabucchi, M. (1975). LSD and dopamine-sensitive adenylate-cyclase in various rat brain areas. *Brain Res* 93, 164–167.
- Spano, P. F., Kumakura, K., & Trabucchi, M. (1976). Dopamine-sensitive adenylate cyclase in the retina: a point of action for D-LSD. *Adv Biochem Psychopharmacol* 15, 357–365.
- Spitzer, M., Thimm, M., Hermle, L., Holzmann, P., Kovar, K. A., Heimann, H., Gouzoulis-Mayfrank, E., Kischka, U., & Schneider, F. (1996). Increased activation of indirect semantic associations under psilocybin. *Biol Psychiatry* 39, 1055–1057.
- Sprouse, J. S., & Aghajanian, G. K. (1987). Electrophysiological responses of serotonergic dorsal raphe neurons to 5-HT<sub>1A</sub> and 5-HT<sub>1B</sub> agonists. *Synapse* 1, 3–9.
- Sprouse, J. S., & Aghajanian, G. K. (1988). Responses of hippocampal pyramidal cells to putative serotonin 5-HT<sub>1A</sub> and 5-HT<sub>1B</sub> agonists: a comparative study with dorsal raphe neurons. *Neuropharmacology* 27, 707–715.
- Steinmetz, J. E. (2000). Brain substrates of classical eyeblink conditioning: a highly localized but also distributed system. *Behav Brain Res* 110, 13–24.
- Steriade, M., Nunez, A., & Amzica, F. (1993). A novel slow (<1 Hz) oscillation of neocortical neurons in vivo: depolarizing and hyperpolarizing components. *J Neurosci* 13, 3252–3265.
- Stewart, O. C. (1987). *Peyote Religion. A History*. Norman, OK: University of Oklahoma Press.
- Strassman, R. J. (1984). Adverse reactions to psychedelic drugs. A review of the literature. *J Nerv Ment Dis* 172, 577–595.
- Strassman, R. J. (1991). Human hallucinogenic drug research in the United States: a present-day case history and review of the process. *J Psychoactive Drugs* 23, 29–38.
- Strassman, R. J. (1995). Hallucinogenic drugs in psychiatric research and treatment. Perspectives and prospects. *J Nerv Ment Dis* 183, 127–138.
- Strassman, R. J. (1996). Human psychopharmacology of *N,N*-dimethyltryptamine. *Behav Brain Res* 73, 121–124.
- Strassman, R. J., & Qualls, C. R. (1994). Dose-response study of *N,N*-dimethyltryptamine in humans: I. Neuroendocrine, autonomic, and cardiovascular effects. *Arch Gen Psychiatry* 51, 85–97.
- Strassman, R. J., Qualls, C. R., Uhlenhuth, E. H., & Kellner, R. (1994). Dose-response study of *N,N*-dimethyltryptamine in humans: II. Subjective effects and preliminary results of a new rating scale. *Arch Gen Psychiatry* 51, 98–108.
- Strassman, R. J., Qualls, C. R., & Berg, L. M. (1996). Differential tolerance to biological and subjective effects of four closely spaced doses of *N,N*-dimethyltryptamine in humans. *Biol Psychiatry* 39, 784–795.
- Stutzmann, G. E., Marek, G. J., & Aghajanian, G. K. (2001). Adenosine preferentially suppresses serotonin<sub>2A</sub> receptor-enhanced excitatory postsynaptic currents in layer V neurons of the rat medial prefrontal cortex. *Neuroscience* 105, 55–69.
- Szara, S. (1970). DMT (*N,N*-dimethyltryptamine) and homologues: clinical and pharmacological considerations. In D.H. Efron (Ed.), *Psychotomimetic Drugs* (pp. 275–286). New York: Raven Press.
- Szara, S., Rockland, L. H., Rosenthal, D., & Handlon, J. H. (1966). Psychological effects and metabolism of *N,N*-diethyltryptamine in man. *Arch Gen Psychiatry* 15, 320–329.
- Tanaka, E., & North, R. A. (1993). Actions of 5-hydroxytryptamine on neurons of the rat cingulate cortex. *J Neurophysiol* 69, 1749–1757.
- Taschner, K. L., & Wanke, K. (1975). Problems of toxic psychosis as illustrated on the example of the so-called LSD psychosis. *Fortschr Med* 93, 1515–1518, 1542.
- Tilakaratne, N., & Friedman, E. (1996). Genomic responses to 5-HT<sub>1A</sub> or 5-HT<sub>2A/2C</sub> receptor activation is differentially regulated in four regions of rat brain. *Eur J Pharmacol* 307, 211–217.
- Titeler, M., Lyon, R. A., & Glennon, R. A. (1988). Radioligand binding evidence implicates the brain 5-HT<sub>2</sub> receptor as a site of action for LSD and phenylisopropylamine hallucinogens. *Psychopharmacology (Berl)* 94, 213–216.
- Tomita, S., Nicoll, R. A., & Bredt, D. S. (2001). PDZ protein interactions regulating glutamate receptor function and plasticity. *J Cell Biol* 153, F19–F24.
- Tononi, G., & Edelman, G. M. (1998). Consciousness and the integration of information in the brain. *Adv Neurol* 77, 245–279.
- Tournois, C., Mutel, V., Manivet, P., Launay, J. M., & Kellermann, O. (1998). Cross-talk between 5-hydroxytryptamine receptors in a serotonergic cell line. Involvement of arachidonic acid metabolism. *J Biol Chem* 273, 17498–17503.
- Tricklebank, M. D., Forler, C., Middlemiss, D. N., & Fozard, J. R. (1985). Subtypes of the 5-HT receptor mediating the behavioural responses to 5-methoxy-*N,N*-dimethyltryptamine in the rat. *Eur J Pharmacol* 117, 15–24.
- Trulson, M. E., Ross, C. A., & Jacobs, B. L. (1977). Lack of tolerance to the depression of raphe unit activity by lysergic acid diethylamide. *Neuropharmacology* 16, 771–774.
- Trulson, M. E., Heym, J., & Jacobs, B. L. (1981). Dissociations between the effects of hallucinogenic drugs on behavior and raphe unit activity in freely moving cats. *Brain Res* 215, 275–293.
- Twarog, B. M. (1988). Serotonin: history of a discovery. *Comp Biochem Physiol C* 91, 21–24.
- Twarog, B. M., & Page, I. H. (1953). *Am J Physiol* 175, 157.
- U'prichard, D. C., Greenberg, D. A., & Snyder, S. H. (1977). Binding characteristics of a radiolabeled agonist and antagonist at central

- nervous system alpha noradrenergic receptors. *Mol Pharmacol* 13, 454–473.
- Udenfriend, S., Weissback, H., & Clark, C. T. (1955). The estimation of 5-hydroxytryptamine (serotonin) in biological tissues. *J Biol Chem* 215, 337–344.
- Umbricht, D., Vollenweider, F. X., Schmid, L., Grubel, C., Skrabo, A., Huber, T., & Koller, R. (2003). Effects of the 5-HT<sub>2A</sub> agonist psilocybin on mismatch negativity generation and AX-continuous performance task: implications for the neuropharmacology of cognitive deficits in schizophrenia. *Neuropsychopharmacology* 28, 170–181.
- Vardy, M. M., & Kay, S. R. (1983). LSD psychosis or LSD-induced schizophrenia? A multimethod inquiry. *Arch Gen Psychiatry* 40, 877–883.
- Vollenweider, F. X. (1998). Advances and pathophysiological models of hallucinogenic drug actions in humans: a preamble to schizophrenia research. *Pharmacopsychiatry* 31 (Suppl 2), 92–103.
- Vollenweider, F. X. (2001). Brain mechanisms of hallucinogens and entactogens. *Dialogues Clin Neurosci* 3, 265–279.
- Vollenweider, F. X., & Geyer, M. A. (2001). A systems model of altered consciousness: integrating natural and drug-induced psychoses. *Brain Res Bull* 56, 495–507.
- Vollenweider, F. X., Leenders, K. L., Scharfetter, C., Antonini, A., Maguire, P., Missimer, J., & Angst, J. (1997). Metabolic hyperfrontality and psychopathology in the ketamine model of psychosis using positron emission tomography (PET) and [<sup>18</sup>F]fluorodeoxyglucose (FDG). *Eur Neuropsychopharmacol* 7, 9–24.
- Vollenweider, F. X., Leenders, K. L., Scharfetter, C., Maguire, P., Stadelmann, O., & Angst, J. (1997). Positron emission tomography and fluorodeoxyglucose studies of metabolic hyperfrontality and psychopathology in the psilocybin model of psychosis. *Neuropsychopharmacology* 16, 357–372.
- Vollenweider, F. X., Vollenweider-Scherpenhuyzen, M. F., Babler, A., Vogel, H., & Hell, D. (1998). Psilocybin induces schizophrenia-like psychosis in humans via a serotonin-2 agonist action. *NeuroReport* 9, 3897–3902.
- Vollenweider, F. X., Vontobel, P., Hell, D., & Leenders, K. L. (1999). 5-HT modulation of dopamine release in basal ganglia in psilocybin-induced psychosis in man—a PET study with [<sup>11</sup>C]raclopride. *Neuropsychopharmacology* 20, 424–433.
- Von Hungen, K., Roberts, S., & Hill, D. F. (1974). LSD as an agonist and antagonist at central dopamine receptors. *Nature* 252, 588–589.
- Votava, Z., Podvalova, I., & Semonsky, M. (1958). Studies on the pharmacology of D-lysergic acid cycloalkylamides. *Arch Int Pharmacodyn Ther* 115, 114–130.
- Walker, E.A., Yamamoto, T., Hollingsworth, P. J., Smith, C. B., & Woods, J. H. (1991). Discriminative-stimulus effects of quipazine and L-5-hydroxytryptophan in relation to serotonin binding sites in the pigeon. *J Pharmacol Exp Ther* 259, 772–782.
- Wallach, M. B., Hine, B., & Gershon, S. (1974). Cross tolerance or tachyphylaxis among various psychotomimetic agents on cats. *Eur J Pharmacol* 29, 89–92.
- Wang, C. D., Gallaher, T. K., & Shih, J. C. (1993). Site-directed mutagenesis of the serotonin 5-hydroxytryptamine<sub>2</sub> receptor: identification of amino acids necessary for ligand binding and receptor activation. *Mol Pharmacol* 43, 931–940.
- Wasson, R. G., & Ingalls, D. H. (1971). The soma of the Rig Veda: what was it? *J Am Orient Soc* 91, 169–187.
- Wasson, R. G., Hofmann, A., & Ruck, C. A. P. (1978). *The Road to Eleusis. Unveiling the Secret of the Mysteries*. New York: Harcourt Brace Jovanovich.
- Watts, V. J., Lawler, C. P., Fox, D. R., Neve, K. A., Nichols, D. E., & Mailman, R. B. (1995). LSD and structural analogs: pharmacological evaluation at D<sub>1</sub> dopamine receptors. *Psychopharmacology (Berl)* 118, 401–409.
- Weinstein, H., Osman, R., & Mercier Jr., G. (1988). Recognition and activation of a 5-HT receptor by hallucinogens and indole derivatives. *NIDA Res Monogr* 90, 243–255.
- Weinstein, H., Zhang, D., & Ballesteros, J. A. (1994). Hallucinogens acting at 5-HT receptors: toward a mechanistic understanding at atomic resolution. *NIDA Res Monogr* 146, 241–262.
- Whitaker, P. M., & Seeman, P. (1977). Hallucinogen binding to dopamine/neuroleptic receptors. *J Pharm Pharmacol* 29, 506–507.
- Williams, R. L. (1999). Mammalian phosphoinositide-specific phospholipase C. *Biochim Biophys Acta* 1441, 255–267.
- Williams, J. T., Colmers, W. F., & Pan, Z. Z. (1988). Voltage- and ligand-activated inwardly rectifying currents in dorsal raphe neurons in vitro. *J Neurosci* 8, 3499–3506.
- Williams, G. V., Rao, S. G., & Goldman-Rakic, P. S. (2002). The physiological role of 5-HT<sub>2A</sub> receptors in working memory. *J Neurosci* 22, 2843–2854.
- Willins, D. L., & Meltzer, H. Y. (1997). Direct injection of 5-HT<sub>2A</sub> receptor agonists into the medial prefrontal cortex produces a head-twitch response in rats. *J Pharmacol Exp Ther* 282, 699–706.
- Willins, D. L., Deutch, A. Y., & Roth, B. L. (1997). Serotonin 5-HT<sub>2A</sub> receptors are expressed on pyramidal cells and interneurons in the rat cortex. *Synapse* 27, 79–82.
- Wing, L. L., Tapson, G. S., & Geyer, M. A. (1990). 5HT-2 mediation of acute behavioral effects of hallucinogens in rats. *Psychopharmacology (Berl)* 100, 417–425.
- Winter, J. C. (1971). Tolerance to a behavioral effect of lysergic acid diethylamide and cross-tolerance to mescaline in the rat: absence of a metabolic component. *J Pharmacol Exp Ther* 178, 625–630.
- Winter, J. C. (1975). Blockade of the stimulus properties of mescaline by a serotonin antagonist. *Arch Int Pharmacodyn Ther* 214, 250–253.
- Winter, J. C. (1994). The stimulus effects of serotonergic hallucinogens in animals. *NIDA Res Monogr* 146, 157–182.
- Winter, J. C., & Rabin, R. A. (1988). Interactions between serotonergic agonists and antagonists in rats trained with LSD as a discriminative stimulus. *Pharmacol Biochem Behav* 30, 617–624.
- Winter, J. C., Fiorella, D. J., Timineri, D. M., Filipink, R. A., Helsley, S.E., & Rabin, R. A. (1999). Serotonergic receptor subtypes and hallucinogen-induced stimulus control. *Pharmacol Biochem Behav* 64, 283–293.
- Winter, J. C., Doat, M., & Rabin, R. A. (2000a). Potentiation of DOM-induced stimulus control by non-competitive NMDA antagonists: a link between the glutamatergic and serotonergic hypotheses of schizophrenia. *Life Sci* 68, 337–344.
- Winter, J. C., Filipink, R. A., Timineri, D., Helsley, S.E., & Rabin, R.A. (2000b). The paradox of 5-methoxy-*N,N*-dimethyltryptamine: an indoleamine hallucinogen that induces stimulus control via 5-HT<sub>1A</sub> receptors. *Pharmacol Biochem Behav* 65, 75–82.
- Wise, R. A. (1998). Drug-activation of brain reward pathways. *Drug Alcohol Depend* 51, 13–22.
- Wolbach, A. B., Miner, E. J., & Isbell, H. (1962). Comparison of psilocin with psilocybin, mescaline, and LSD. *Psychopharmacologia (Berl)* 3, 219–223.
- Wong, D. F., Lever, J. R., Hartig, P. R., Dannals, R. F., Villemagne, V., Hoffman, B. J., Wilson, A. A., Ravert, H. T., Links, J. M., & Scheffel, U. (1987). Localization of serotonin 5-HT<sub>2</sub> receptors in living human brain by positron emission tomography using *N*1-([<sup>11</sup>C]-methyl)-2-Br-LSD. *Synapse* 1, 393–398.
- Woolley, D. W., & Shaw, E. (1954a). A biochemical and pharmacological suggestion about certain mental disorders. *Science* 119, 587–588.
- Woolley, D. W., & Shaw, E. (1954b). A biochemical and pharmacological suggestion about certain mental disorders. *Proc Natl Acad Sci USA* 40, 228–231.
- Wright, D. E., Seroogy, K. B., Lundgren, K. H., Davis, B. M., & Jennes, L. (1995). Comparative localization of serotonin<sub>1A</sub>, <sub>1C</sub>, and <sub>2</sub> receptor subtype mRNAs in rat brain. *J Comp Neurol* 351, 357–373.
- Xia, Z., Gray, J.A., Compton-Toth, B. A., & Roth, B. L. (2003). A direct interaction of PSD-95 with 5-HT<sub>2A</sub> serotonin receptors regulates receptor trafficking and signal transduction. *J Biol Chem* 278, 21901–21908.
- Xu, Z. Q., Zhang, X., Pieribone, V. A., Grillner, S., & Hokfelt, T. (1998). Galanin-5-hydroxytryptamine interactions: electrophysiological, immunohistochemical and in situ hybridization studies on rat dorsal raphe

- neurons with a note on galanin R1 and R2 receptors. *Neuroscience* 87, 79–94.
- Yamamoto, T., Walker, E. A., & Woods, J. H. (1991). Agonist and antagonist properties of serotonergic compounds in pigeons trained to discriminate either quipazine or L-5-hydroxytryptophan. *J Pharmacol Exp Ther* 258, 999–1007.
- Yan, Q. S. (2000). Activation of 5-HT<sub>2A/2C</sub> receptors within the nucleus accumbens increases local dopaminergic transmission. *Brain Res Bull* 51, 75–81.
- Yensen, R., Di Leo, F. B., Rhead, J. C., Richards, W. A., Soskin, R. A., Turek, B., & Kurland, A. A. (1976). MDA-assisted psychotherapy with neurotic outpatients: a pilot study. *J Nerv Ment Dis* 163, 233–245.
- Yocca, F. D., Wright, R. N., Margraf, R. R., & Eison, A. S. (1990). 8-OH-DPAT and buspirone analogs inhibit the ketanserin-sensitive quipazine-induced head shake response in rats. *Pharmacol Biochem Behav* 35, 251–254.
- Yritia, M., Riba, J., Ortuno, J., Ramirez, A., Castillo, A., Alfaro, Y., de la, T. R., & Barbanj, M. J. (2002). Determination of *N,N*-dimethyltryptamine and beta-carboline alkaloids in human plasma following oral administration of ayahuasca. *J Chromatogr B Analyt Technol Biomed Life Sci* 779, 271–281.
- Zhai, Y., George, C. A., Zhai, J., Nisenbaum, E. S., Johnson, M. P., & Nisenbaum, L. K. (2003). Group II metabotropic glutamate receptor modulation of DOI-induced *c-fos* mRNA and excitatory responses in the cerebral cortex. *Neuropsychopharmacology* 28, 45–52.
- Zhou, F. M., & Hablitz, J. J. (1999). Activation of serotonin receptors modulates synaptic transmission in rat cerebral cortex. *J Neurophysiol* 82, 2989–2999.
- Zoli, M., Torri, C., Ferrari, R., Jansson, A., Zini, I., Fuxe, K., & Agnati, L. F. (1998). The emergence of the volume transmission concept. *Brain Res Brain Res Rev* 26, 136–147.